

92mm sq.

San Ace 92L



General Specifications

- Material Frame: Aluminum,
Impeller: Plastics (Flammability: UL94V-1)
- Expected Life Refer to specifications (L10:Survival rate:90% at 60°C ,
rated voltage, and continuously run in a free air state)
- Lead Wire ⊕red ⊖black (Sensor) yellow (Control) brown
- Storage Temperature -30°C to +70°C (Non-condensing)

92×92×25mm (Mass : 150g) **9LG type** **High Airflow**

Specifications

The following nos. **have PWM controls and pulse sensors.**

Model No.	Rated Voltage [V]	Operating Voltage Range [V]	PWM duty cycle Normal [%]	Rated Current [A]	Rated Input [W]	Rated Speed [min ⁻¹]	Max. Airflow [m ³ /min] [CFM]	Max. Static Pressure [Pa] [inchH ₂ O]	SPL [dB(A)]	Operating Temperature [°C]	Expected Life [h]
9LG0912P4J001	12	10.8 to 13.2	100	0.42	5.04	5,000	2.20 77.7	105 0.42	44	-20 to +70	180,000/60°C
9LG0912P4G001			100	0.30	3.60	4,400	1.93 68.2	81 0.33	40		
9LG0912P4S001			100	0.22	2.64	3,850	1.69 59.7	62.1 0.25	37		
9LG0912P4H001			100	0.15	1.80	3,150	1.38 48.7	41.6 0.17	32		
9LG0924P4J001	24	21.6 to 26.4	100	0.21	5.04	5,000	2.20 77.7	105 0.42	44		
9LG0924P4G001			100	0.15	3.60	4,400	1.93 68.2	81 0.33	40		
9LG0924P4S001			100	0.11	2.64	3,850	1.69 59.7	62.1 0.25	37		
9LG0924P4H001			100	0.07	1.68	3,150	1.38 48.7	41.6 0.17	32		

Note : Fan does not rotate when PWM duty cycle is 0%.

※PWM Frequency : 25kHz

Other sensor specifications are available as options. Please refer to the index (p. 509).

Dimensions (unit: mm)

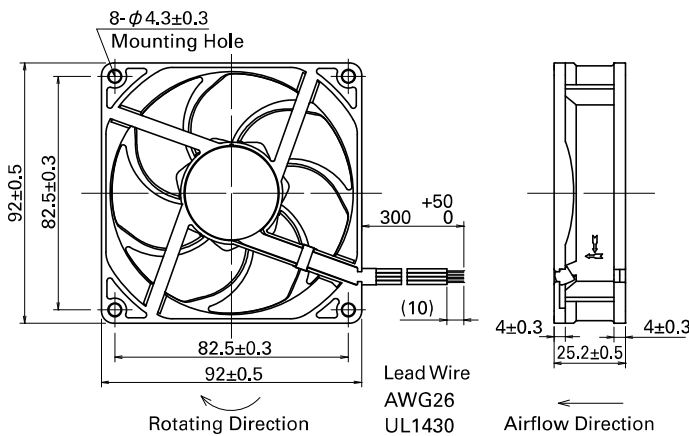

Reference Dimensions of Mounting Holes and Vent Opening (unit: mm)

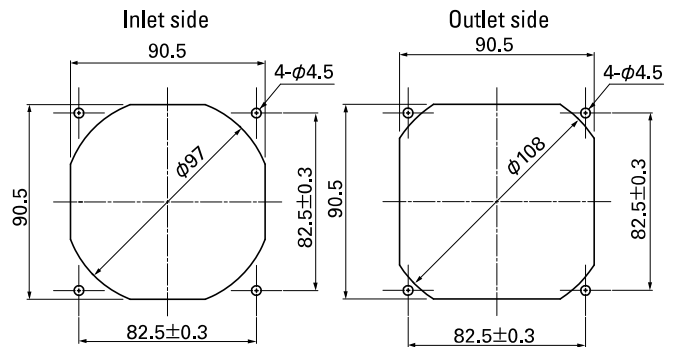

Options (unit: mm)

Finger Guards

Model : 109-099C Surface treatment : Nickel-chrome plating (silver) Color : Nickel-chrome plating (silver)

Model : 109-099E Surface treatment : Nickel-chrome plating (silver) Color : Nickel-chrome plating (silver)
Model : 109-099H Surface treatment : Cation electropainting (black) Color : Cation electropainting (black)

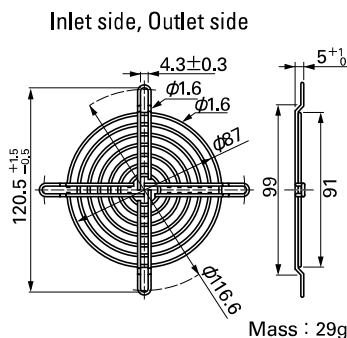
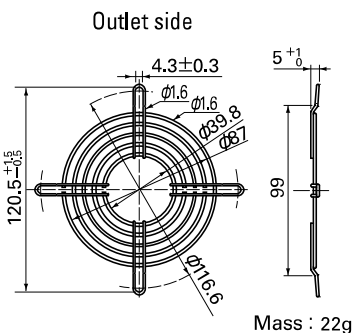

Options (unit: mm)

Resin Finger Guards

Model : 109-1001G

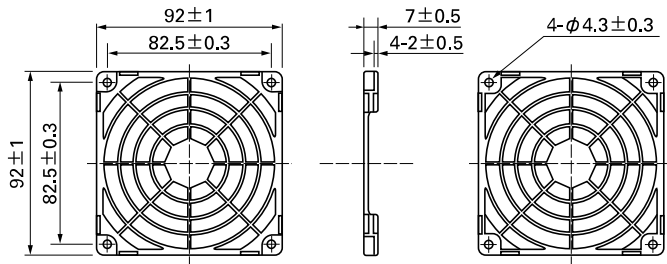

Mass : 12g

Resin Filter Kits

Model : 109-1001F13 (13PPI), 109-1001F20 (20PPI)
: 109-1001F30 (30PPI), 109-1001F40 (40PPI)

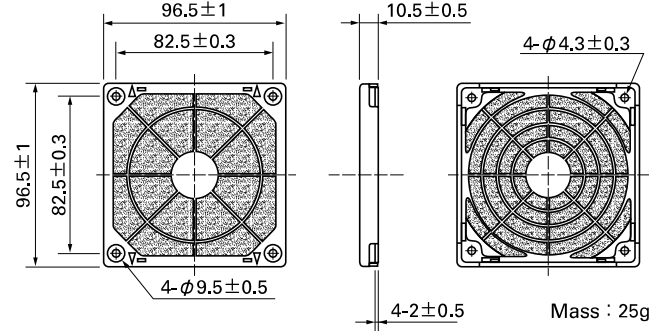

Mass : 25g

Airflow - Static Pressure Characteristics

PWM Duty Cycle

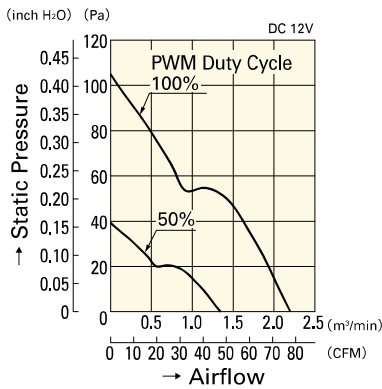

9LG0912P4J001

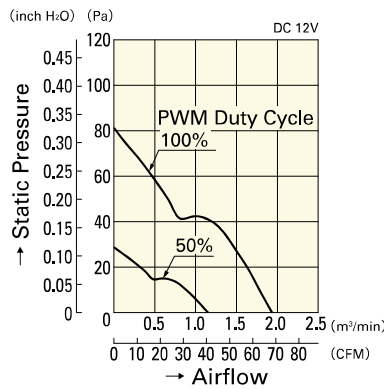

9LG0912P4G001

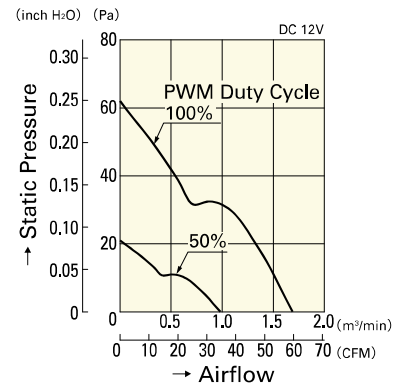

9LG0912P4S001

Operating Voltage Range

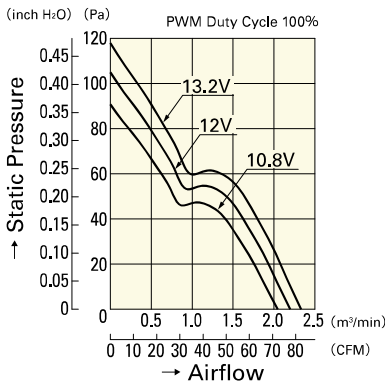

9LG0912P4J001

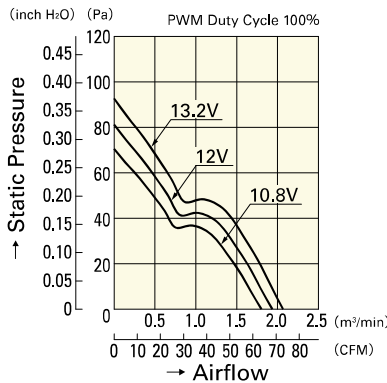

9LG0912P4G001

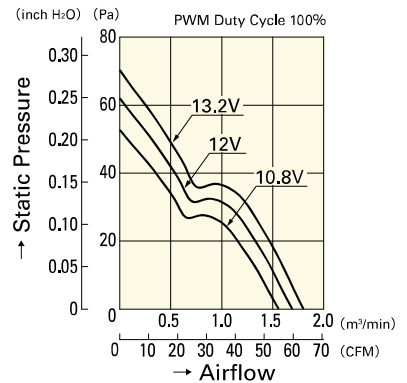

9LG0912P4S001

PWM Duty - Speed Characteristics Example

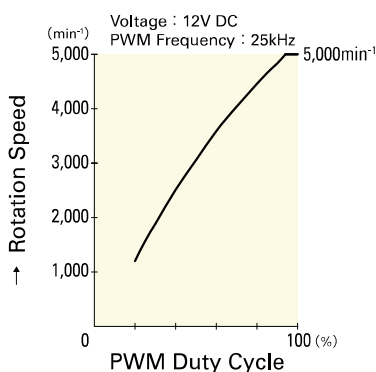

9LG0912P4J001

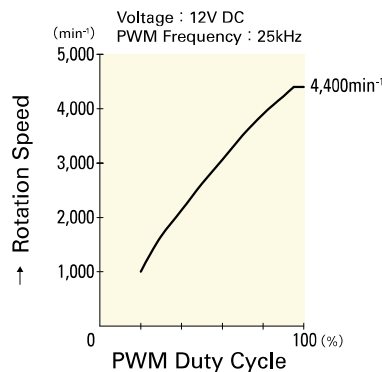

9LG0912P4G001

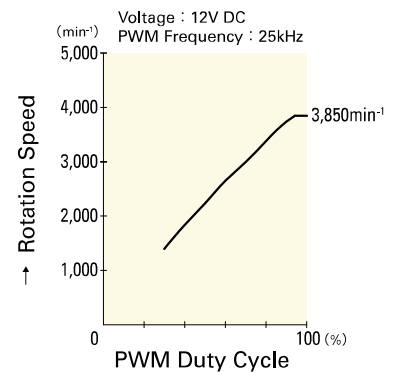

9LG0912P4S001

DC

Long Life Fan 92mm

92mm sq.

San Ace 92L

92×92×25mm [Mass : 150g]

Airflow - Static Pressure Characteristics

PWM Duty Cycle

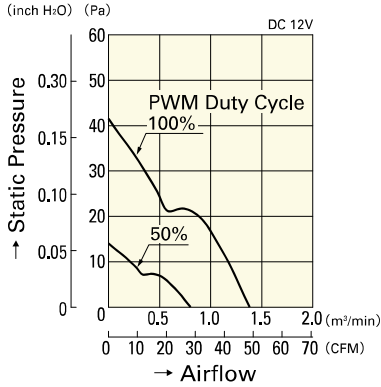

9LG0912P4H001

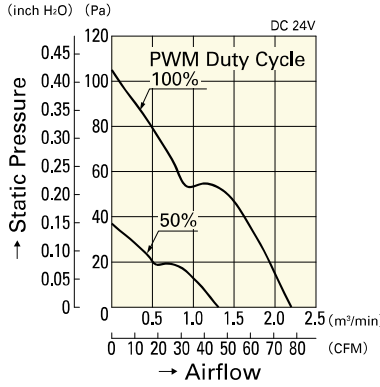

9LG0924P4J001

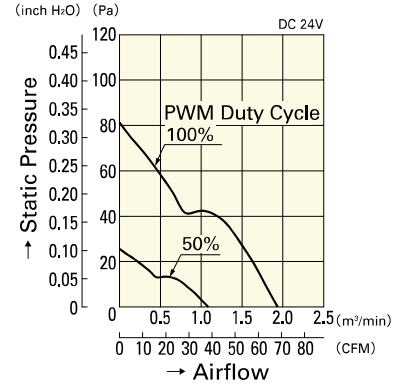

9LG0924P4G001

Operating Voltage Range

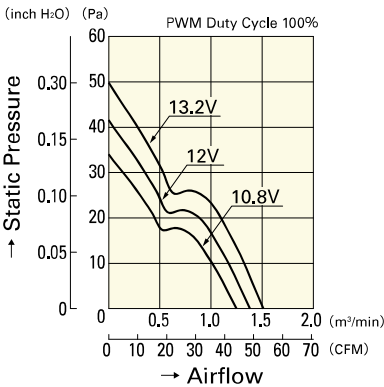

9LG0912P4H001

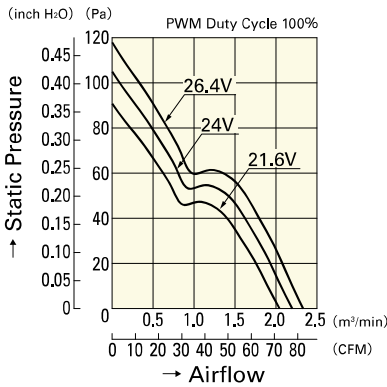

9LG0924P4J001

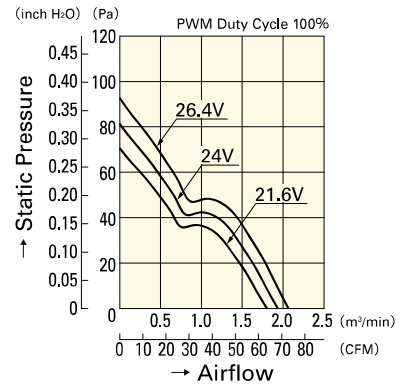

9LG0924P4G001

PWM Duty - Speed Characteristics Example

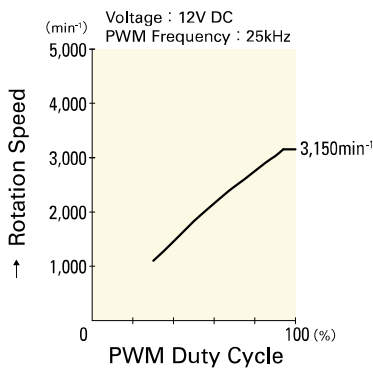

9LG0912P4H001

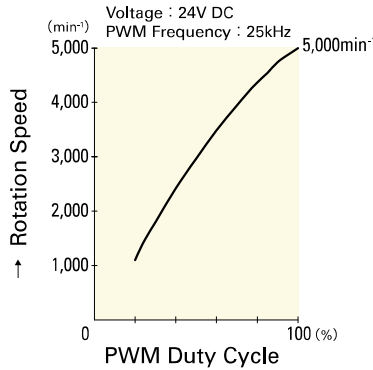

9LG0924P4J001

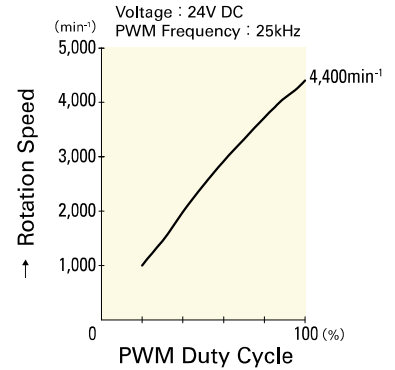

9LG0924P4G001

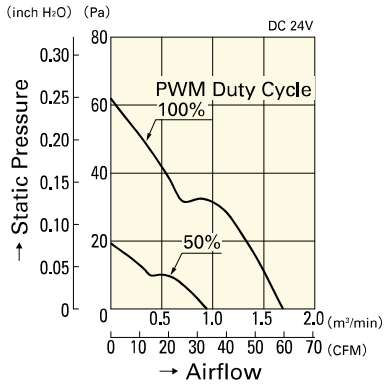

9LG0924P4S001

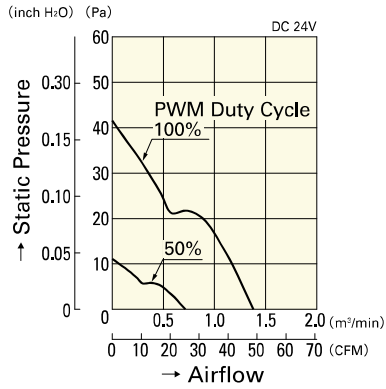

9LG0924P4H001

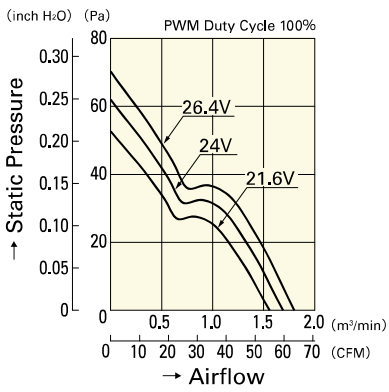

9LG0924P4S001

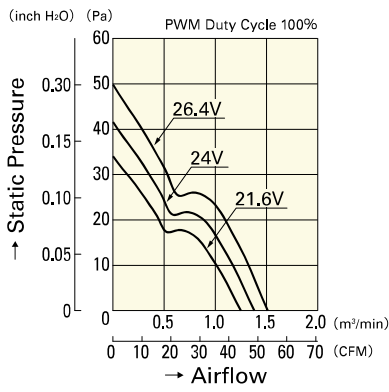

9LG0924P4H001

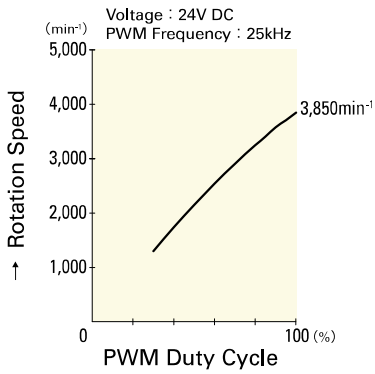

9LG0924P4S001

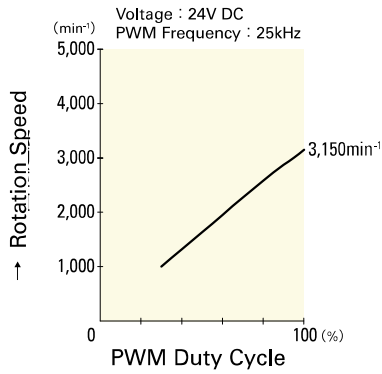

9LG0924P4H001