

# 80mm sq.

## San Ace 80W



### General Specifications

- Material ..... Frame: Plastics (Flammability: UL94V-0),  
Impeller: Plastics (Flammability: UL94V-1)
- Expected Life ..... Refer to specifications (Indoor, L10: Survival rate: 90% at 60°C ,  
rated voltage, and continuously run in a free air state)
- Lead Wire ..... ⊕red ⊖black (Sensor) yellow (Control) brown
- Storage Temperature ..... -30°C to +70°C (Non-condensing)

## 80×80×38mm [Mass : 235g] IP 68 9WV type

**Specifications** The following nos. **have PWM controls, pulse sensors, and ribs.** For ribless, append "1" to the model no.

Model No.	Rated Voltage [V]	Operating Voltage Range [V]	PWM duty cycle* [%]	Rated Current [A]	Rated Input [W]	Rated Speed [min <sup>-1</sup> ]	Max. Airflow [m <sup>3</sup> /min] [CFM]	Max. Static Pressure [Pa] [inchH <sub>2</sub> O]	SPL [dB(A)]	Operating Temperature [°C]	Expected Life [h]
9WV0812P1M001	12	10.2 to 13.8	100	0.75	9	6,000	2.29 80.9	169 0.68	51	-20 to +70	40,000/60°C (70,000/40°C)
			0	0.09	1.08	1,700	0.65 23	13.6 0.05	19		
9WV0848P1H001	48	40.8 to 52.8	100	0.75	36	9,700	3.7 131	440 1.77	63	-20 to +70	40,000/60°C (70,000/40°C)
			0	0.15	7.2	4,500	1.72 60.7	94.7 0.38	43		

\*PWM Frequency : 25kHz

Other sensor specifications are available as options. Please refer to the index (p. 513).

### Dimensions (unit: mm) (With ribs)

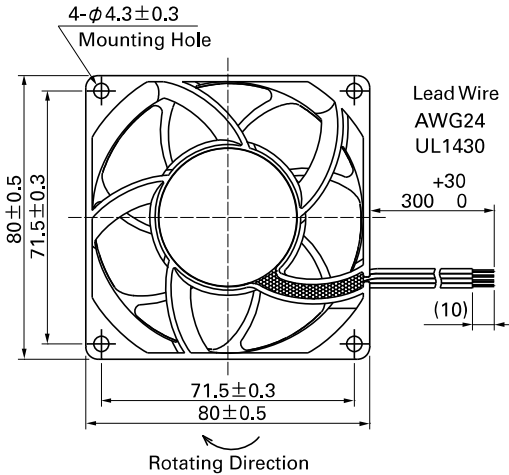

### Reference Dimensions of Mounting Holes and Vent Opening (unit: mm)

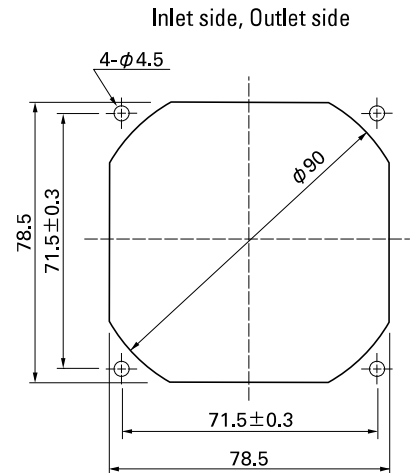

### Options (unit: mm)

#### Finger Guards

Model : 109-049C Surface treatment : Nickel-chrome plating (silver) Color

Model : 109-049E Surface treatment : Nickel-chrome plating (silver) Color  
: 109-049H : Cation electropainting (black)

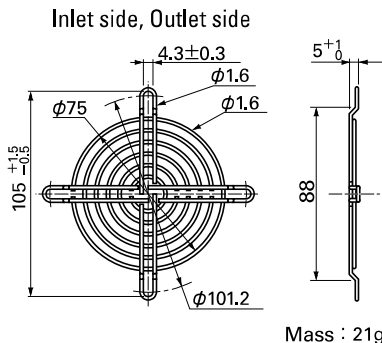
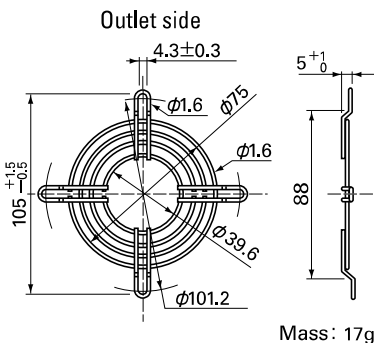

**Options (unit: mm)**

**Resin Finger Guards**

Model : 109-1002G

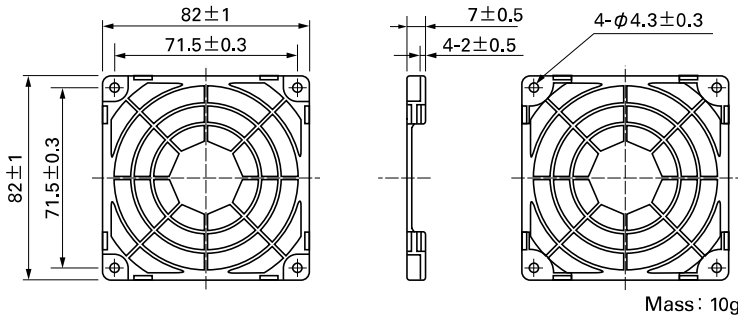

**Airflow - Static Pressure Characteristics**

**PWM Duty Cycle**

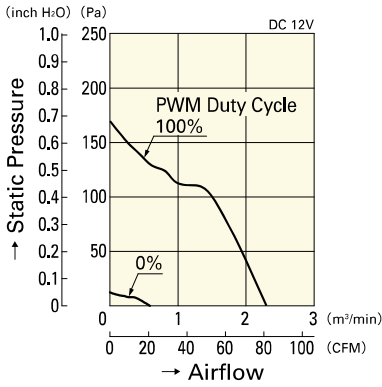

**9WV0812P1M001**

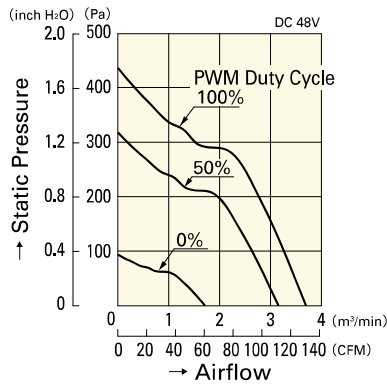

**9WV0848P1H001**

**Operating Voltage Range**

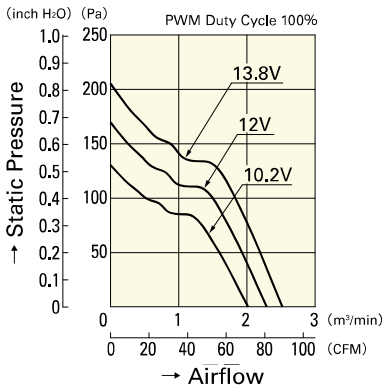

**9WV0812P1M001**

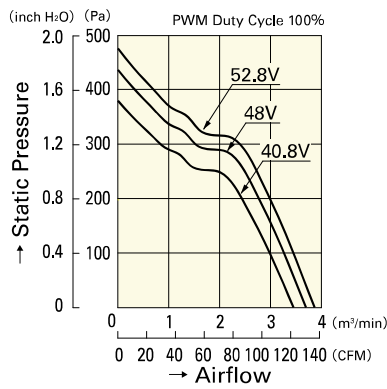

**9WV0848P1H001**

**PWM Duty - Speed Characteristics Example**

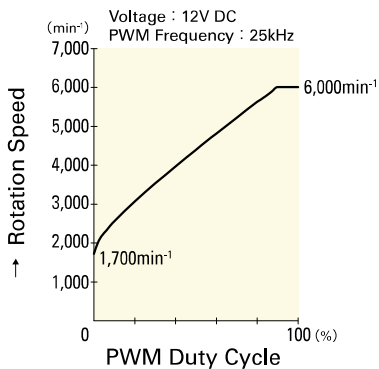

**9WV0812P1M001**

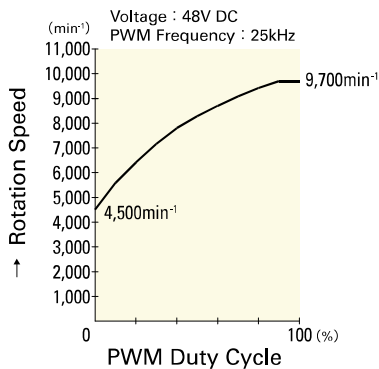

**9WV0848P1H001**