

92mm sq.

San Ace 92W



General Specifications

- Material Frame: Plastics (Flammability: UL94V-0),
Impeller: Plastics (Flammability: UL94V-1)
- Expected Life Refer to specifications (Indoor, L10: Survival rate: 90% at 60°C ,
rated voltage, and continuously run in a free air state)
- Lead Wire ⊕red ⊖black (Sensor) yellow (Control) brown
- Storage Temperature -30°C to +70°C (Non-condensing)

92×92×38mm [Mass : 265g] **IP 68** **9WV**type

Specifications

The following nos. have PWM controls, pulse sensors, and ribs.

Model No.	Rated Voltage [V]	Operating Voltage Range [V]	PWM duty cycle* [%]	Rated Current [A]	Rated Input [W]	Rated Speed [min ⁻¹]	Max. Airflow [m ³ /min] [CFM]	Max. Static Pressure [Pa] [inchH ₂ O]	SPL [dB(A)]	Operating Temperature [°C]	Expected Life [h]
9WV0924P1H001	24	20.4 to 26.4	100	1.6	38.4	8,500	5.05 178	385 1.55	64	-20 to +60	30,000/60°C
			20	0.16	3.84	3,000	1.78 62.9	47.9 0.19	38		
9WV0948P1H001	48	40.8 to 52.8	100	0.82	39.4	8,500	5.05 178	385 1.55	64	-20 to +70	30,000/60°C
			0	0.14	6.7	4,000	2.37 83.7	85.2 0.34	45		

*PWM Frequency : 25kHz

Dimensions (unit: mm)

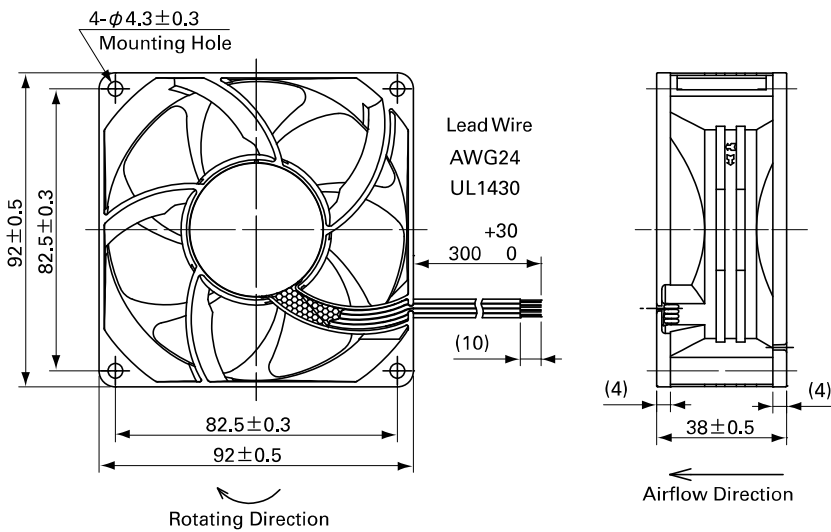

Options (unit: mm)

Finger Guards

Model : 109-099C Surface treatment : Nickel-chrome plating Color (silver)

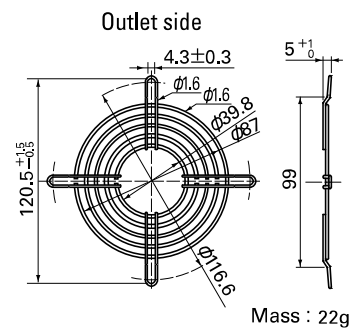

Model : 109-099E Surface treatment : Nickel-chrome plating Color (silver)
: 109-099H : Cation electropainting (black)

Inlet side, Outlet side

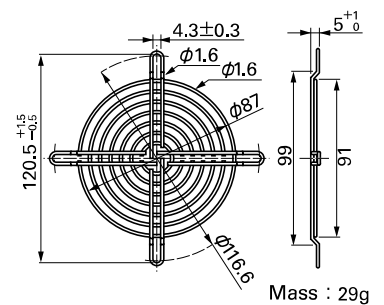

Reference Dimensions of Mounting Holes and Vent Opening (unit: mm)

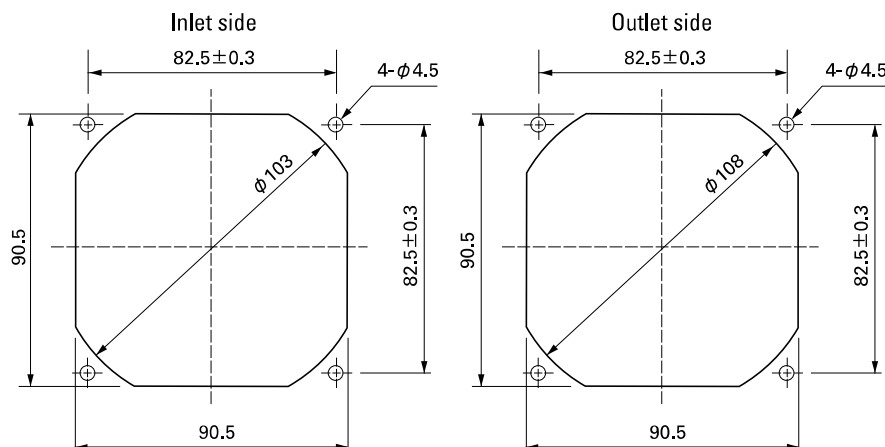

Options (unit: mm)

Resin Finger Guards

Model : 109-1001G

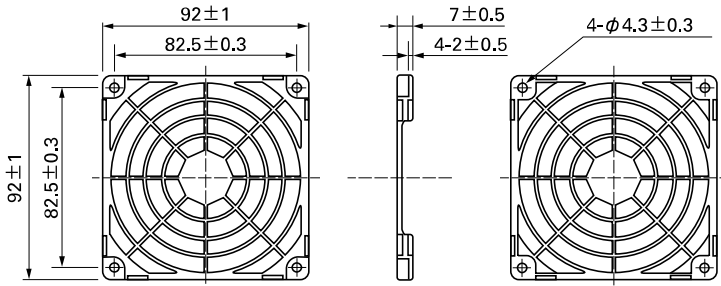

Mass : 12g

Airflow - Static Pressure Characteristics

PWM Duty Cycle

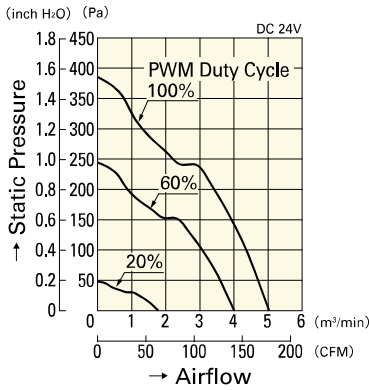

9WV0924P1H001

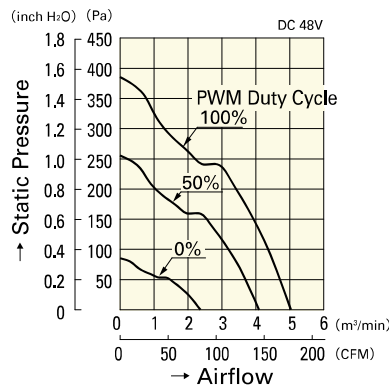

9WV0948P1H001

Operating Voltage Range

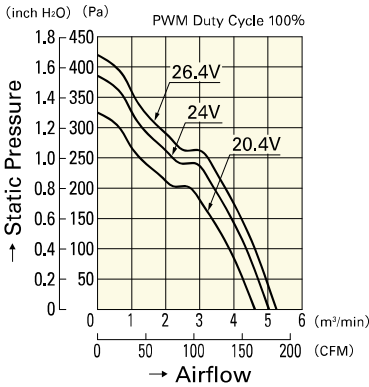

9WV0924P1H001

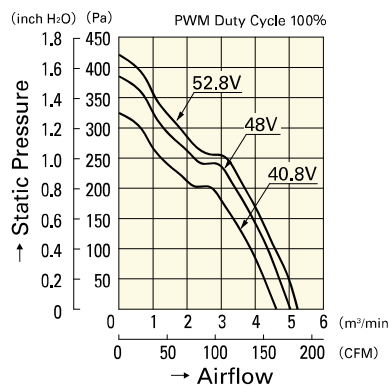

9WV0948P1H001

PWM Duty - Speed Characteristics Example

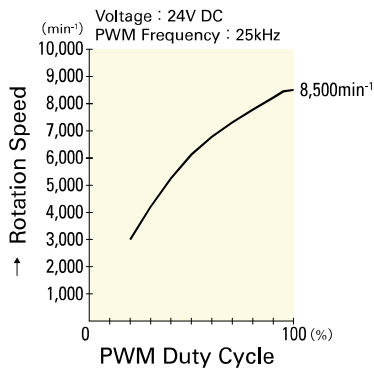

9WV0924P1H001

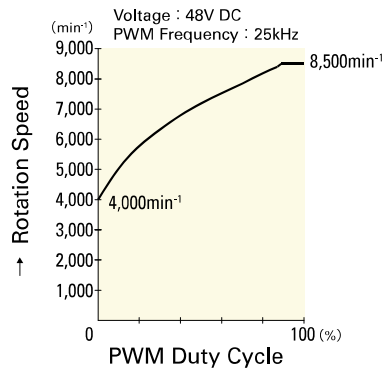

9WV0948P1H001