

φ 100_{mm}

San Ace C100

25mm thick (9TM type)



General Specifications

- Material: Motor case: Aluminum, Impeller: Plastics (Flammability: UL94V-0)
- Expected Life: Refer to specifications (L10:Survival rate: 90% at 60°C, rated voltage, and continuously run in a free air state)
- Lead Wire: ⊕red ⊖black (Sensor) yellow (Control) brown
- Storage Temperature: -30°C to +70°C (Non-condensing)

φ 100mm × 25mm (Mass : 150g) **9TM type**

Specifications When our inlet nozzle [Option (Model NO. : 109-1080)] is mounted. The following nos. **have PWM controls and pulse sensors.**

Model No.	Rated Voltage [V]	Operating Voltage Range [V]	PWM duty cycle* [%]	Rated Current [A]	Rated Input [W]	Rated Speed [min ⁻¹]	Max. Airflow [m ³ /min] [CFM]	Max. Static Pressure [Pa] [inchH ₂ O]	SPL [dB(A)]	Operating Temperature [°C]	Expected Life [h]
9TM48P4H01	48	36 to 60	100	0.22	10.56	6,400	1.77 62.5	560 2.25	60	-20 to +70	40,000
			0	0.04	1.92	2,000	0.51 18.0	48 0.19	34		

Note : Max input is 14W at rated voltage.

※ PWM Frequency : 25kHz

Dimensions (unit : mm)

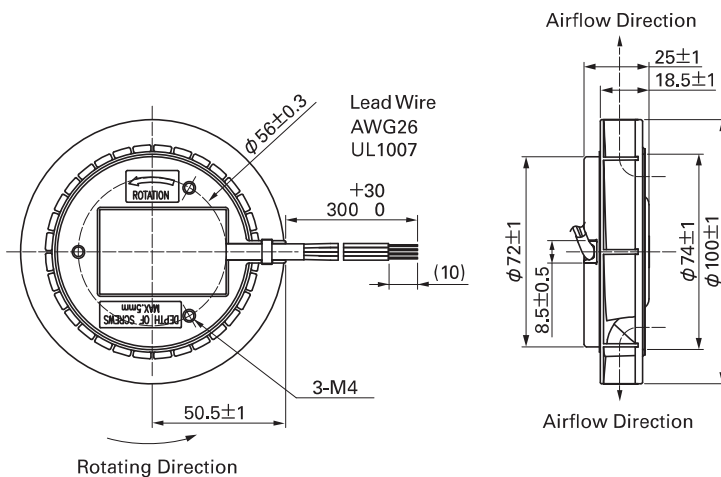

Reference Dimension of Mounting Holes and Vent Opening (unit : mm)

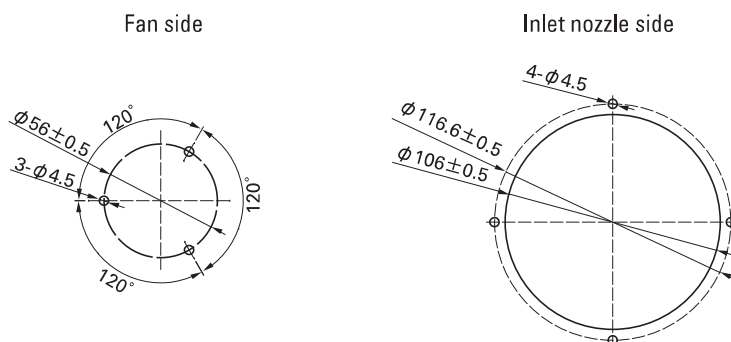

Options (unit : mm)

Inlet Nozzle

Model : 109-1080 Material: Steel sheet Surface treatment: Electro nickel plating (silver) Color

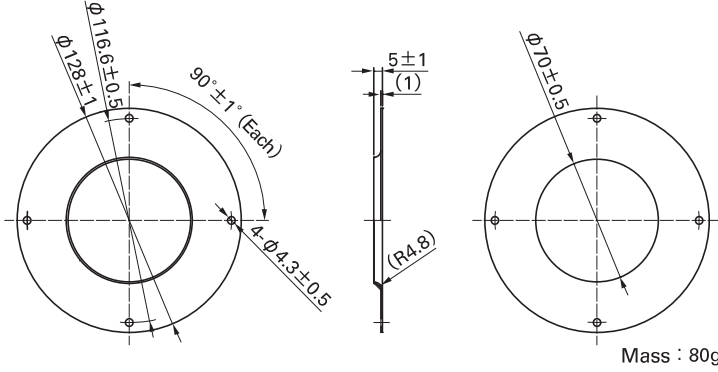

Finger Guards

Model : 109-099E Surface treatment : Nickel-chrome plating (silver) Color : 109-099H : Cationelectroplating (black)

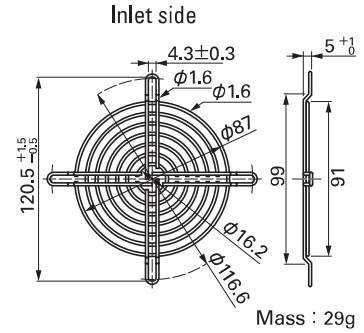

Inlet nozzle : Nozzle mounted in fan inlet side to adjust the flow of introduced air

Referance Diagram for Mounting

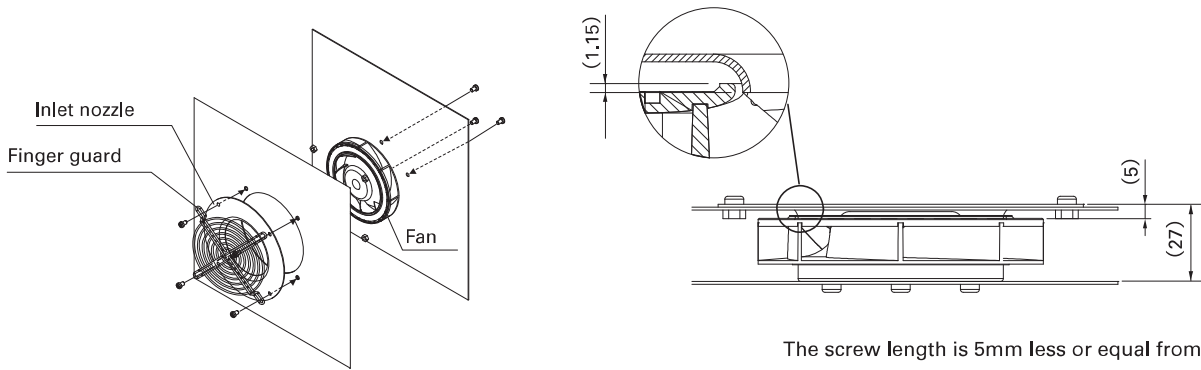

The screw length is 5mm less or equal from fan edge side.

Airflow - Static Pressure Characteristics

PWM Duty Cycle

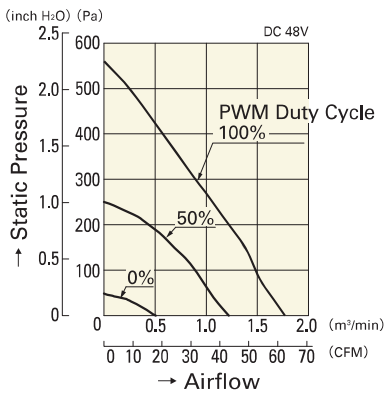

9TM48P4H01

Operating Voltage Range

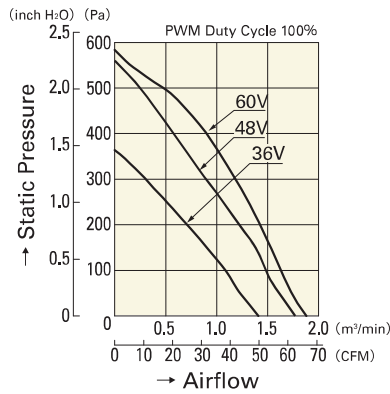

9TM48P4H01

PWM Duty - Speed Characteristics Example

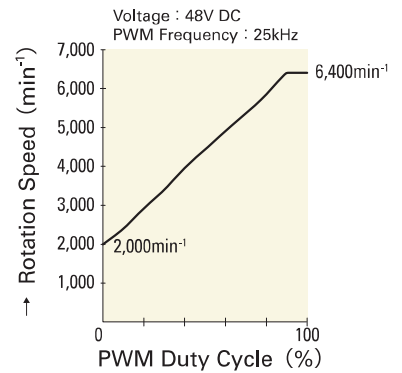

9TM48P4H01