

φ172_{mm}

San Ace 172



General Specifications

- Material Frame: Aluminum, Impeller: Plastics (Flammability: UL94V-0)
- Expected Life Refer to specifications (L10:Survival rate:90% at 60°C , rated voltage, and continuously run in a free air state)
- Lead Wire Inlet ⊕ red ⊖ black (Sensor) yellow (Control) brown
Outlet ⊕ orange ⊖ gray (Sensor) purple (Control) white
- Storage Temperature -30°C to +70°C (Non-condensing)

φ172mm × 150mm × 102mm (Mass : 1,600g) **9CR type**

Specifications

The following nos. **have PWM controls and pulse sensors.**

Model No.	Rated Voltage [V]	Operating Voltage Range [V]	PWM duty cycle* [%]	Rated Current [A]	Rated Input [W]	Rated Speed [min ⁻¹]		Max. Airflow [m ³ /min] [CFM]		Max. Static Pressure [Pa] [inchH ₂ O]		SPL [dB(A)]	Operating Temperature [°C]	Expected Life [h]
						Inlet	Outlet							
9CR5748P9G001	48	36 to 72	100	5.5	264	7,300	6,400	18	636	1,400	5.62	83	-20 to +70	40,000/60°C
			0	0.5	24	2,400	1,900	5.5	194.3	152	0.61	54		

*PWM Frequency : 25kHz

Dimensions (unit: mm)

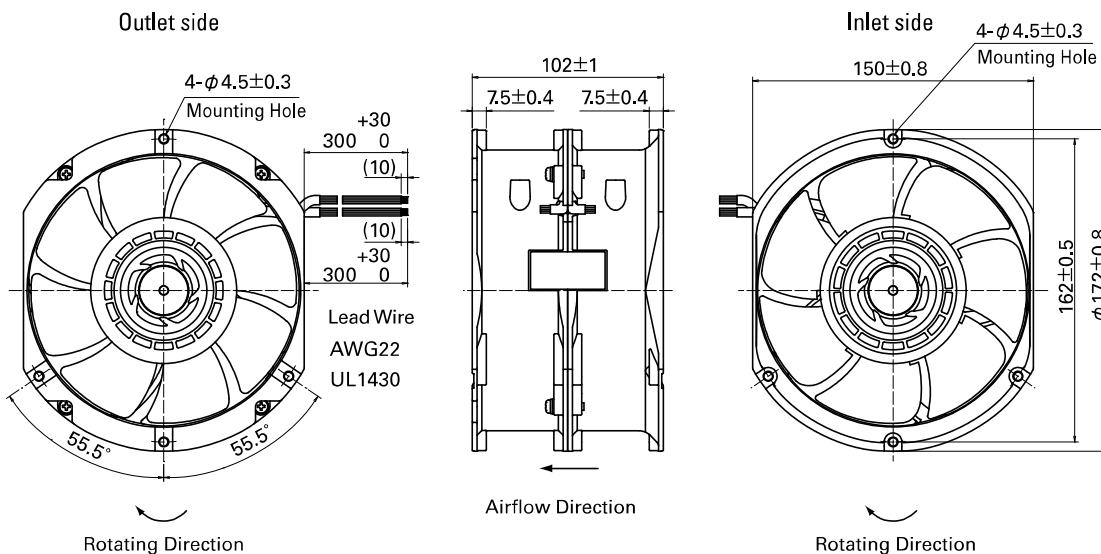

Reference Dimensions of Mounting Holes and Vent Opening (unit: mm)

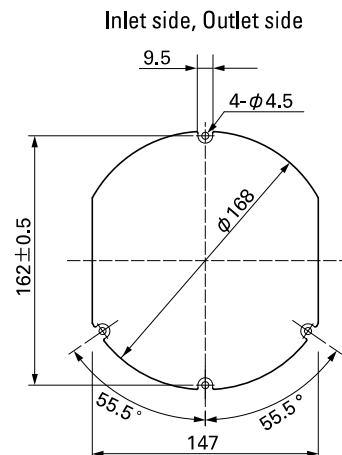

Options (unit: mm)

Finger Guards

Model : 109-319J Color Surface treatment : Nickel-chrome plating (silver)

Inlet side, Outlet side

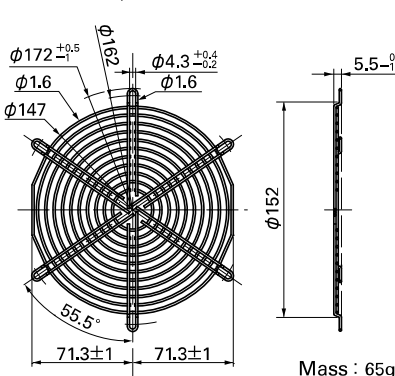

Finger guard 109-319J should be mounted with four holes as in the drawing.

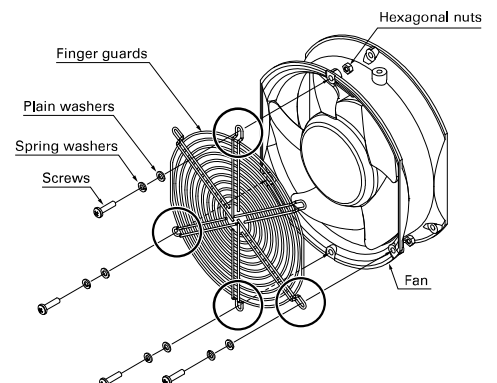

Options (unit: mm)

Finger Guards

Color
 Model : 109-319E Surface treatment : Nickel-chrome plating (silver)
 : 109-319H : Cation electropainting (black)

Color
 Model : 109-320 Surface treatment : Nickel-chrome plating (silver)

Finger guards 109-319E, 109-319H, and 109-320 should be mounted with two holes as in the drawing and do not use any other holes.

Inlet side, Outlet side

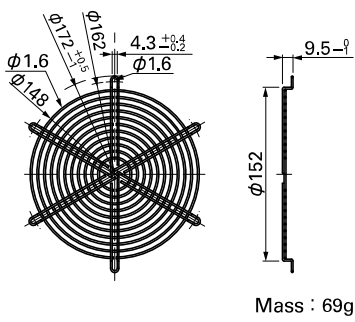

Outlet side

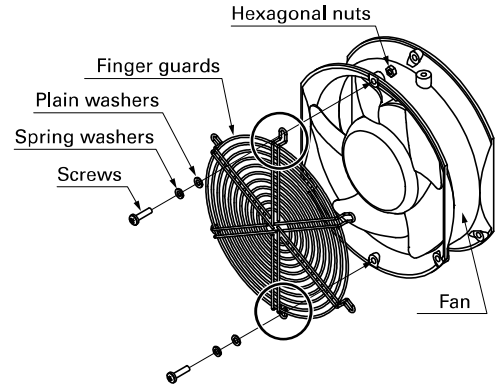
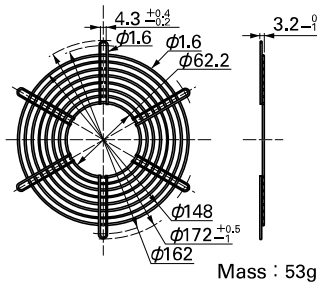

Airflow - Static Pressure Characteristics

PWM Duty Cycle

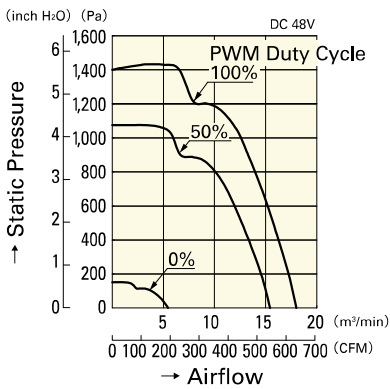

9CR5748P9G001

Operating Voltage Range

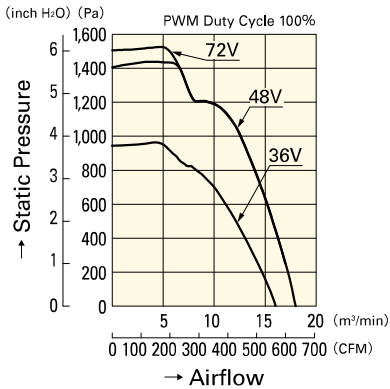

9CR5748P9G001

PWM Duty - Speed Characteristics Example

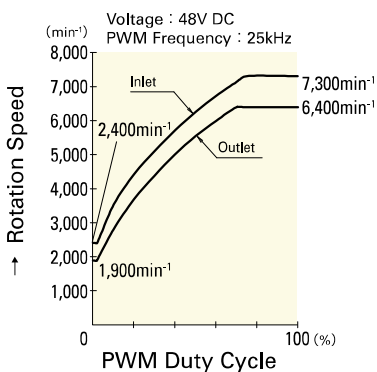

9CR5748P9G001