

120mm sq.

San Ace 120



General Specifications

- Material Frame: Plastics (Flammability: UL94V-0),
Impeller: Plastics (Flammability: UL94V-1)
- Expected Life Refer to specifications (L10:Survival rate:90% at 60°C ,
rated voltage, and continuously run in a free air state)
- Lead Wire ⊕red ⊖black (Sensor) yellow (Control) brown
- Storage Temperature -30°C to +70°C (Non-condensing)

120×120×25mm (Mass : 260g) **9GV type**

Specifications

The following nos. **have PWM controls, pulse sensors, and ribs.** For ribless, append "1" to the model no.

Model No.	Rated Voltage [V]	Operating Voltage Range [V]	PWM duty cycle* [%]	Rated Current [A]	Rated Input [W]	Rated Speed [min ⁻¹]	Max. Airflow [m ³ /min] [CFM]	Max. Static Pressure [Pa] [inchH ₂ O]	SPL [dB(A)]	Operating Temperature [°C]	Expected Life [h]
9GV1212P4G01	12	10.2 to 13.8	100	1.68	20.16	5,100	4.83 171	224 0.90	58	-20 to +70	40,000/60°C
			0	0.18	2.16	1,650	1.56 55.1	23.5 0.09	30		
9GV1224P4G01	24	20.4 to 27.6	100	0.84	20.16	5,100	4.83 171	224 0.90	58		
			0	0.13	3.12	1,650	1.56 55.1	23.5 0.09	30		
9GV1248P4J01	48	40.8 to 55.2	100	0.5	24.00	5,400	5.11 180	251 1.01	59		
			0	0.15	7.20	3,000	2.84 100	77.5 0.31	47		
9GV1248P4G01	48	40.8 to 60.0	100	0.42	20.16	5,100	4.83 171	224 0.90	58		
			0	0.07	3.36	1,650	1.56 55.1	23.5 0.09	30		
9GV1248P4H01	48	40.8 to 60.0	100	0.33	15.84	4,600	4.35 154	182 0.73	55		
			0	0.07	3.36	1,650	1.56 55.1	23.5 0.09	30		

*PWM Frequency : 25kHz

Other sensor specifications are available as options. Please refer to the index (p. 508).

Dimensions (unit: mm)

(With ribs)

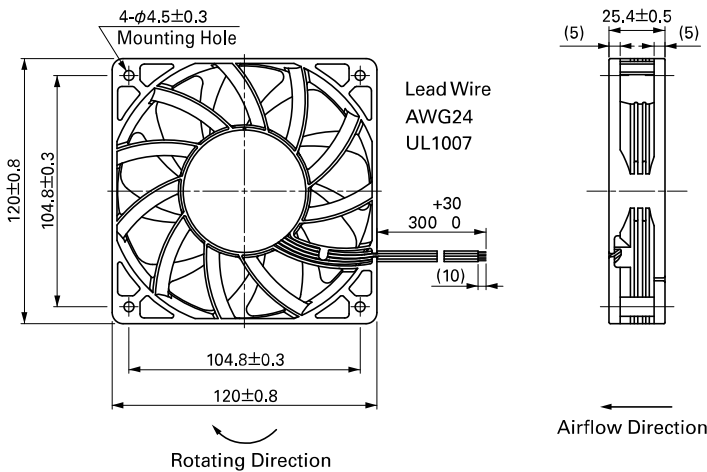

Reference Dimensions of Mounting Holes and Vent Opening (unit: mm)

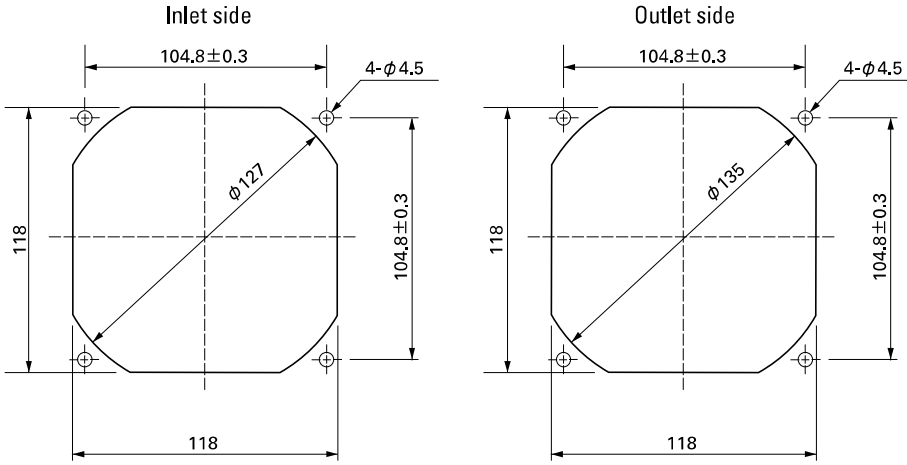

Options (unit: mm)

Finger Guards

Model : 109-019C Surface treatment : Nickel-chrome plating (silver) Color : 109-019H : Cation electropainting (black)

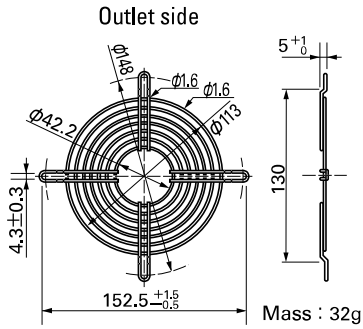

Resin Finger Guards

Model : 109-1000G

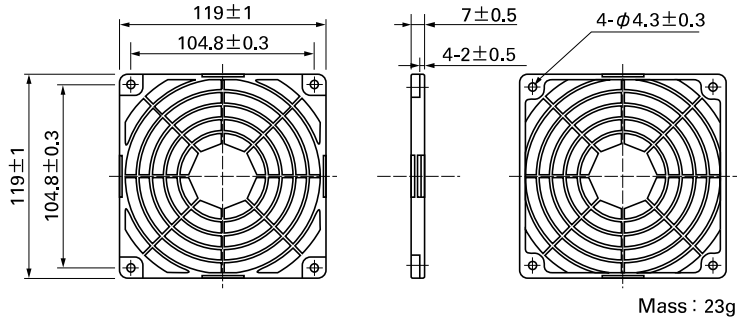

Model : 109-019E Surface treatment : Nickel-chrome plating (silver) Color : 109-019K : Cation electropainting (black)

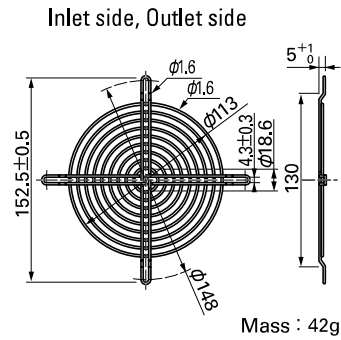

Resin Filter Kits

Model : 109-1000F13 (13PPI), 109-1000F20 (20PPI) : 109-1000F30 (30PPI), 109-1000F40 (40PPI)

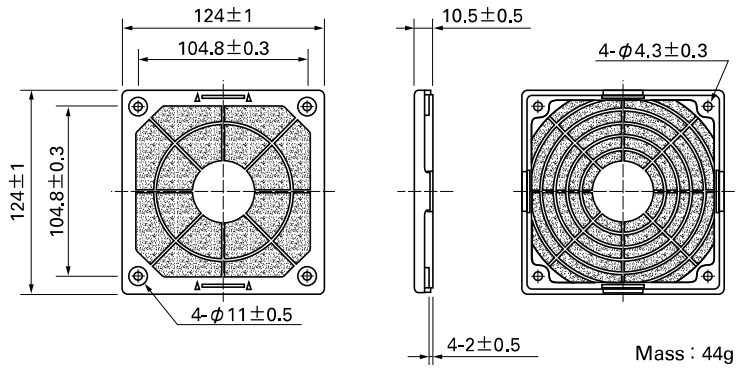

120 mm sq.

San Ace 120

120×120×25 mm [Mass : 260g]

Airflow - Static Pressure Characteristics

PWM Duty Cycle

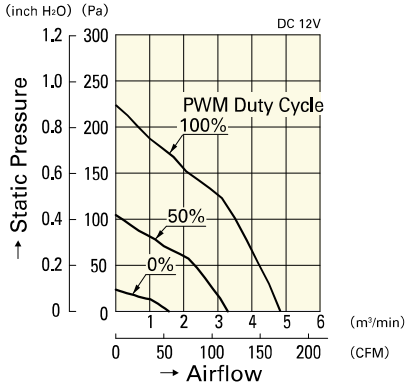

9GV1212P4G01

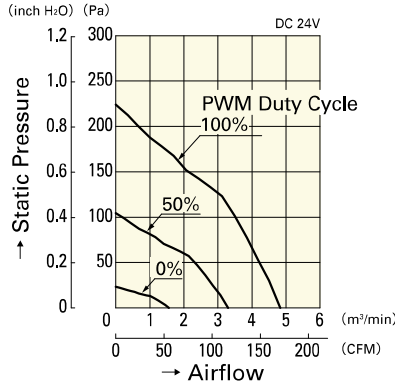

9GV1224P4G01

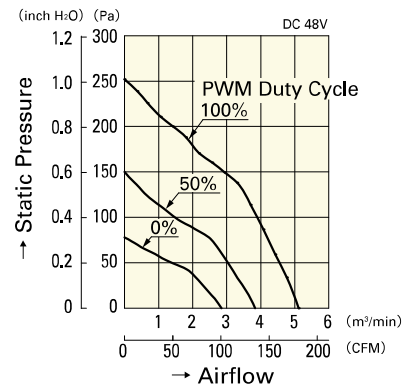

9GV1248P4J01

Operating Voltage Range

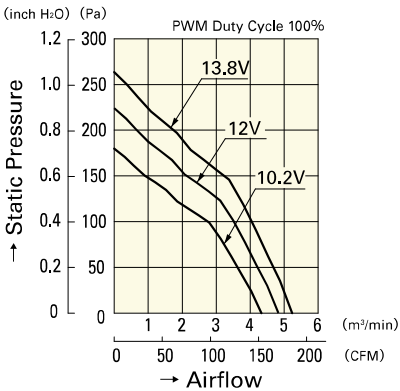

9GV1212P4G01

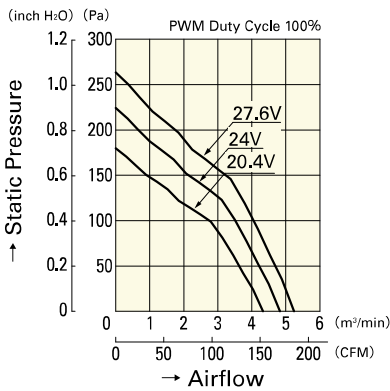

9GV1224P4G01

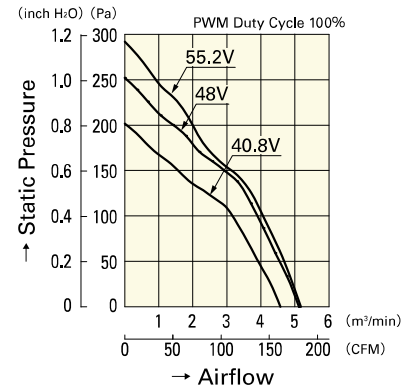

9GV1248P4J01

PWM Duty - Speed Characteristics Example

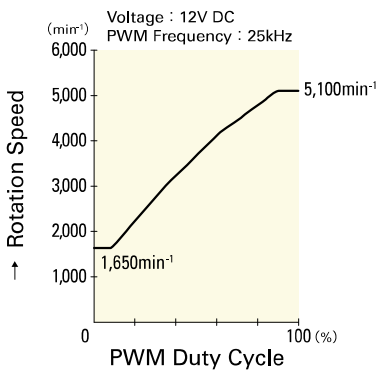

9GV1212P4G01

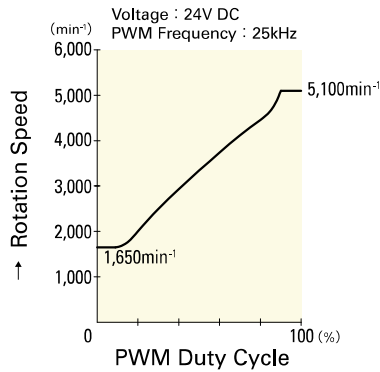

9GV1224P4G01

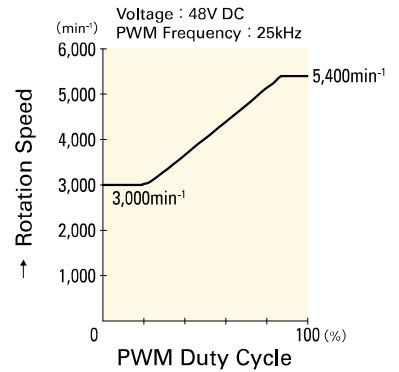

9GV1248P4J01

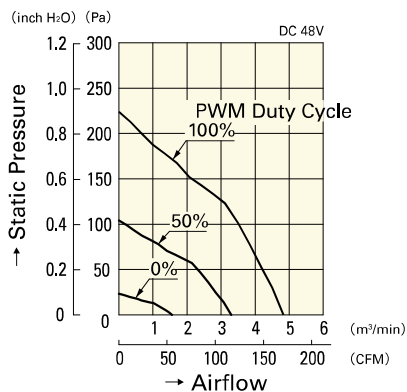

9GV1248P4G01

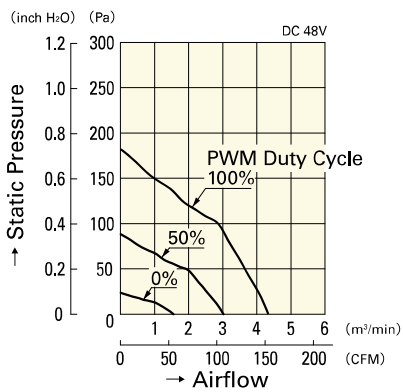

9GV1248P4H01

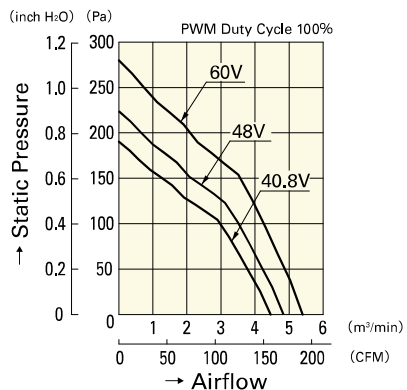

9GV1248P4G01

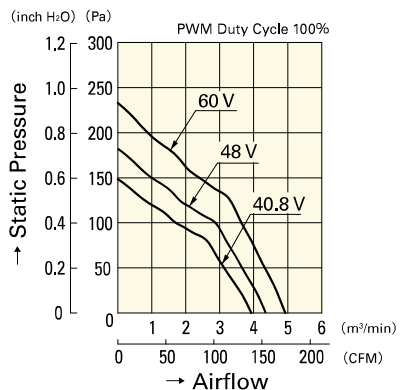

9GV1248P4H01

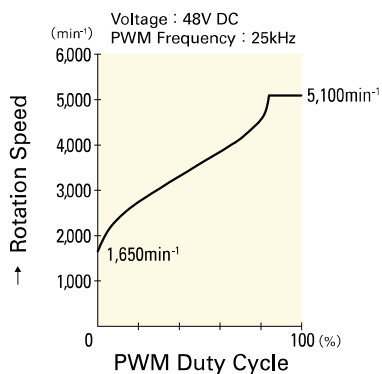

9GV1248P4G01

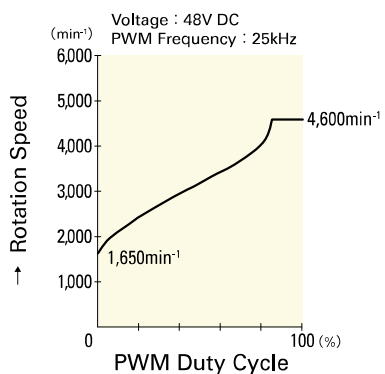

9GV1248P4H01