

**40**mm sq.

# San Ace 40



## General Specifications

- Material ..... Frame: Plastics (Flammability: UL94V-0),  
Impeller: Plastics (Flammability: UL94V-0)
- Expected Life ..... Refer to specifications (L10: Survival rate: 90% at 60°C ,  
rated voltage, and continuously run in a free air state)
- Lead Wire ..... ⊕red ⊖black (Sensor) yellow (Control) brown
- Storage Temperature ..... -30°C to +70°C (Non-condensing)

**40×40×20**mm (Mass : 35g) **9GA type** High Airflow Low Power Consumption Fan



## Specifications The following nos. have PWM controls, pulse sensors, and ribs.

Model No.	Rated Voltage [V]	Operating Voltage Range [V]	PWM duty cycle* [%]	Rated Current [A]	Rated Input [W]	Rated Speed [min <sup>-1</sup> ]	Max. Airflow [m <sup>3</sup> /min] [CFM]	Max. Static Pressure [Pa] [inchH <sub>2</sub> O]	SPL [dB(A)]	Operating Temperature [°C]	Expected Life [h]
9GA0405P6H001 <sup>(Note)</sup>	5	4.5 to 5.5	100	0.35	1.75	12,400	0.33 11.7	191 0.77	40	-20 to +70	40,000/60°C
9GA0405P6F001 <sup>(Note)</sup>			100	0.18	0.9	8,000	0.21 7.4	79.5 0.32	28		60,000/60°C
9GA0412P6G001	12	10.2 to 13.8	100	0.23	2.76	16,000	0.42 14.8	318 1.28	47		40,000/60°C
			0	0.04	0.48	3,800	0.10 3.5	17.9 0.07	14		60,000/60°C
100			0.14	1.68	12,400	0.33 11.7	191 0.77	40			
0			0.04	0.48	3,800	0.10 3.5	17.9 0.07	14			
9GA0412P6H001	12	10.2 to 13.8	100	0.08	0.96	8,000	0.21 7.4	79.5 0.32	28		60,000/60°C
9GA0412P6F001			0	0.03	0.36	2,200	0.06 2.1	6.0 0.02	10		
9GA0424P6G001 <sup>(Note)</sup>	24	20.4 to 27.6	100	0.13	3.12	16,000	0.42 14.8	318 1.28	47		40,000/60°C
9GA0424P6H001 <sup>(Note)</sup>			100	0.08	1.92	12,400	0.33 11.7	191 0.77	40		60,000/60°C
9GA0424P6F001 <sup>(Note)</sup>			100	0.04	0.96	8,000	0.21 7.4	79.5 0.32	28		

Note: Rated voltage 5V and 24V fans do not rotate when PWM duty cycle is 0%.

\*PWM Frequency : 25kHz

Other sensor specifications are available as options. Please refer to the index (p. 504).

## Dimensions (unit: mm)

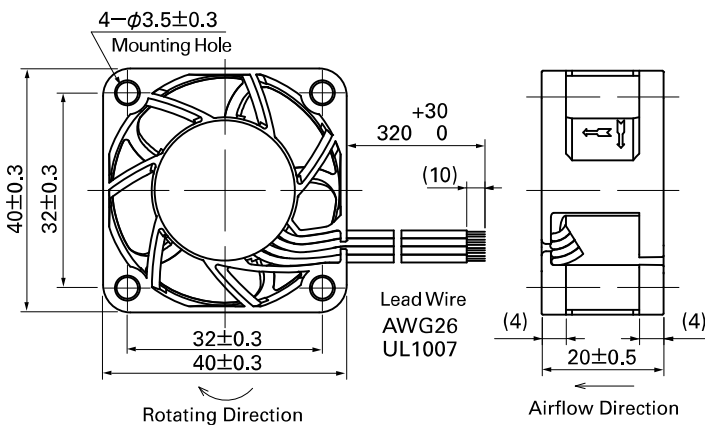

## Reference Dimensions of Mounting Holes and Vent Opening (unit: mm)

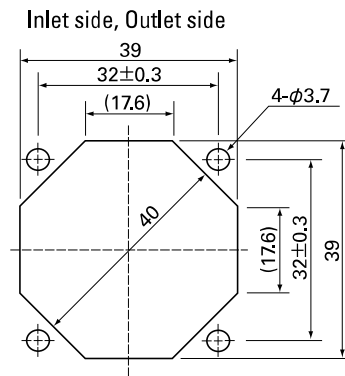

**Options (unit: mm)**

**Finger Guards**

Model : 109-059      Surface treatment : Nickel-chrome plating (silver)  
 : 109-059H          : Cation electropainting (black)

Color

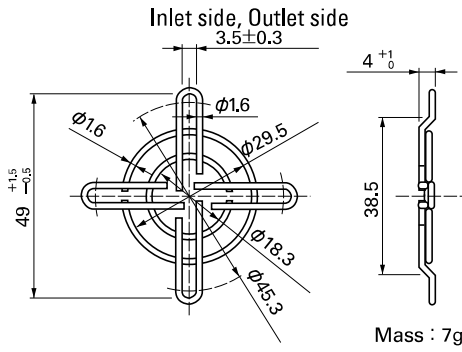

**Airflow - Static Pressure Characteristics**

**PWM Duty Cycle**

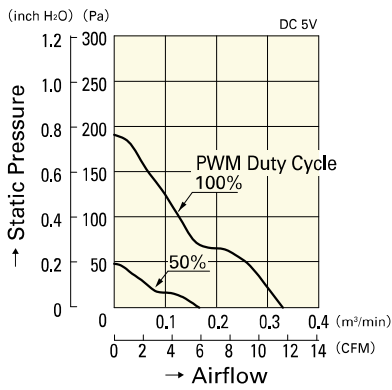

**9GA0405P6H001**

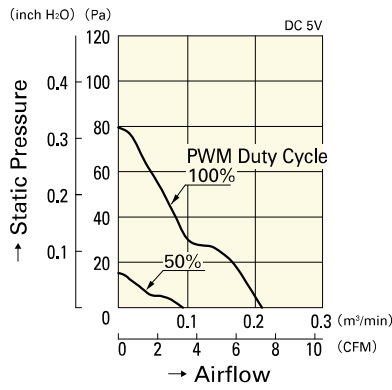

**9GA0405P6F001**

**Operating Voltage Range**

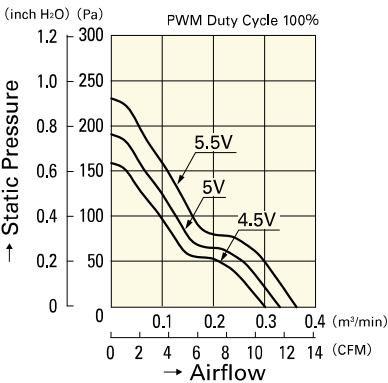

**9GA0405P6H001**

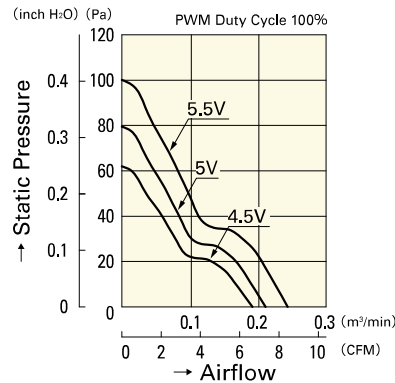

**9GA0405P6F001**

**PWM Duty - Speed Characteristics Example**

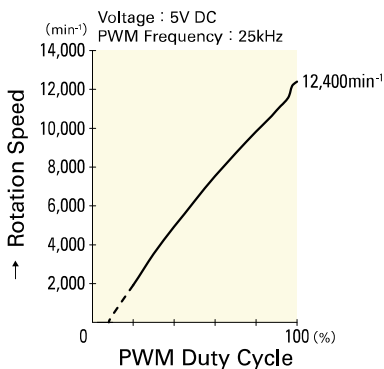

**9GA0405P6H001**

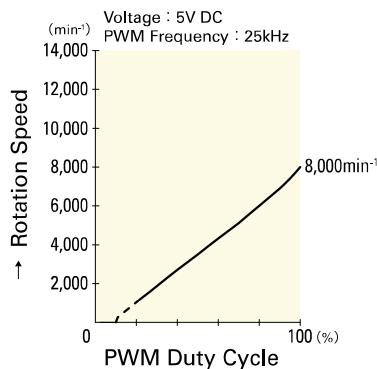

**9GA0405P6F001**

**40**mm sq.

**San Ace 40**

**40×40×20mm** [Mass : 35g]

**Airflow - Static Pressure Characteristics**

**PWM Duty Cycle**

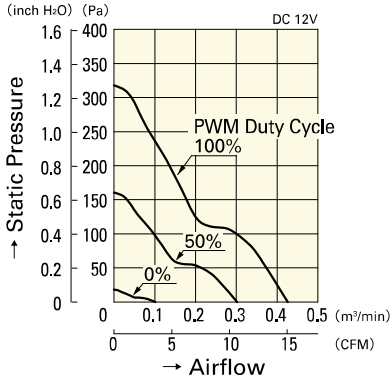

**9GA0412P6G001**

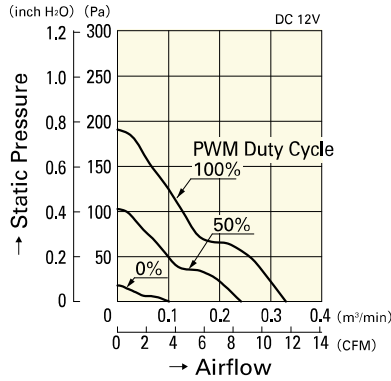

**9GA0412P6H001**

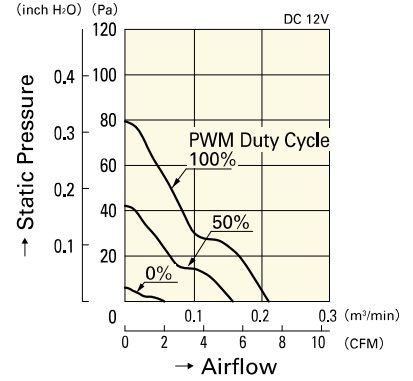

**9GA0412P6F001**

**Operating Voltage Range**

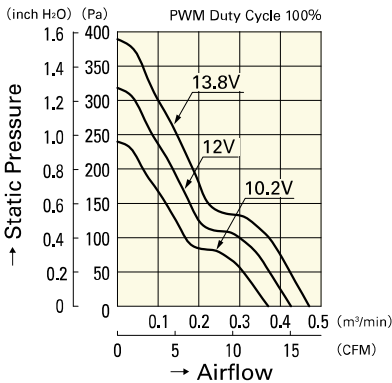

**9GA0412P6G001**

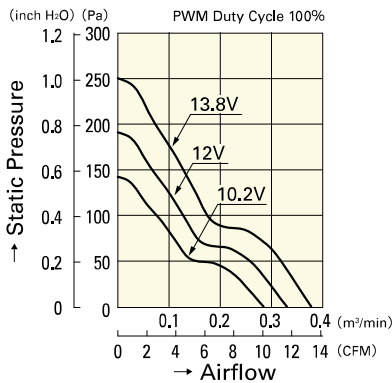

**9GA0412P6H001**

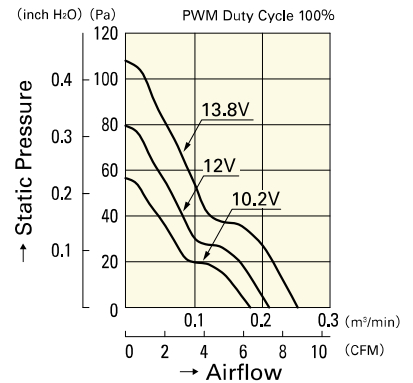

**9GA0412P6F001**

**PWM Duty - Speed Characteristics Example**

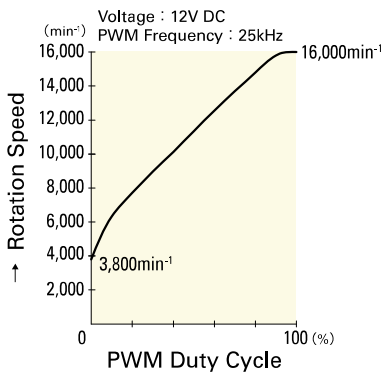

**9GA0412P6G001**

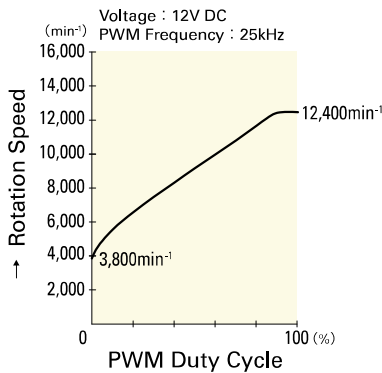

**9GA0412P6H001**

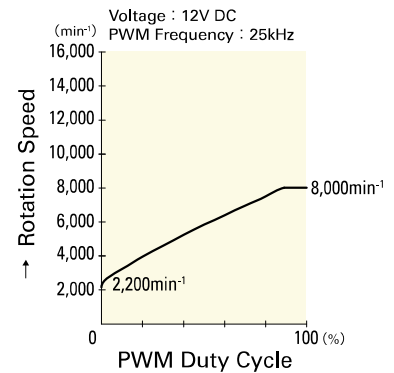

**9GA0412P6F001**

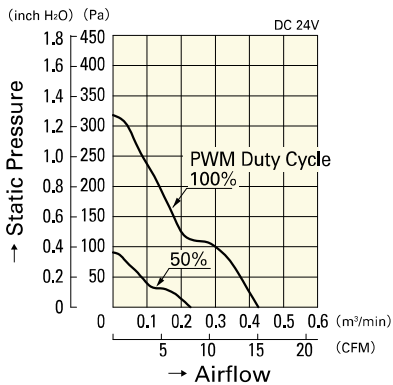

**9GA0424P6G001**

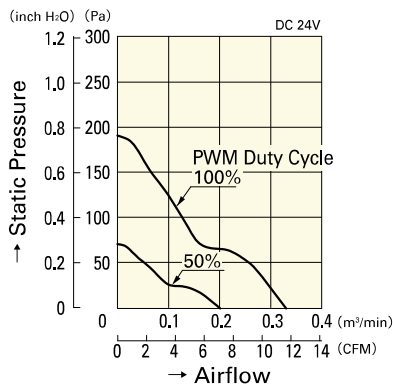

**9GA0424P6H001**

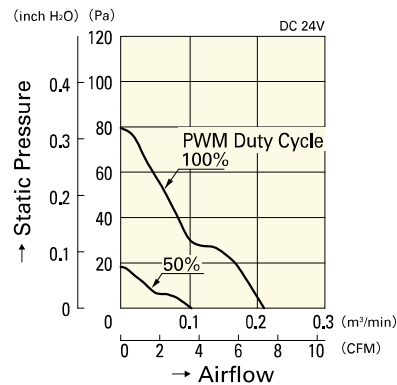

**9GA0424P6F001**

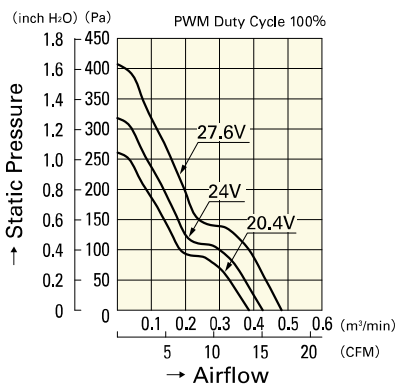

**9GA0424P6G001**

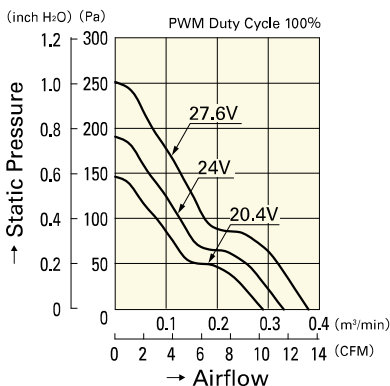

**9GA0424P6H001**

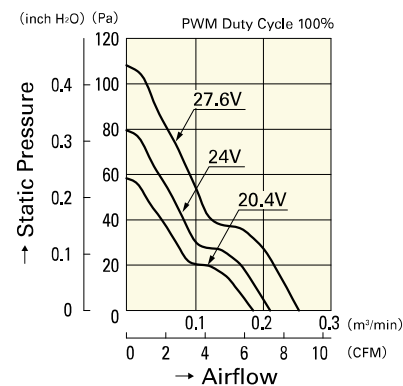

**9GA0424P6F001**

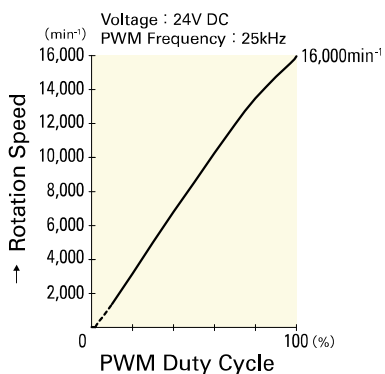

**9GA0424P6G001**

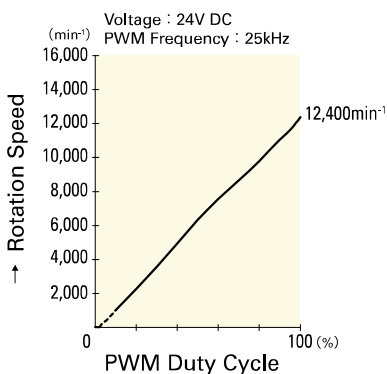

**9GA0424P6H001**

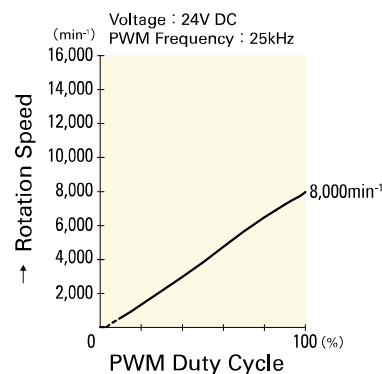

**9GA0424P6F001**