

**60** mm sq.

# San Ace 60



## General Specifications

- Material ..... Frame: Plastics (Flammability: UL94V-0),  
Impeller: Plastics (Flammability: UL94V-1)
- Expected Life ..... Refer to specifications (L10:Survival rate:90% at 60°C ,  
rated voltage, and continuously run in a free air state)
- Lead Wire ..... ⊕red ⊖black or blue (Sensor) yellow
- Storage Temperature ..... -30°C to +70°C (Non-condensing)

**60×60×25**mm (Mass : 90g) **9R** type

**Specifications** The following nos. **have pulse sensors and ribs.** For ribless, append "1" to the model no.

Model No.	Rated Voltage [V]	Operating Voltage Range [V]	Rated Current [A]	Rated Input [W]	Rated Speed [min <sup>-1</sup> ]	Max. Airflow [m <sup>3</sup> /min] [CFM]	Max. Static Pressure [Pa] [inchH <sub>2</sub> O]	SPL [dB(A)]	Operating Temperature [°C]	Expected Life [h]		
<b>109R0605H401</b>	5	4.5 to 5.5	0.34	1.70	3,800	0.53 18.7	40.2 0.161	28	-20 to +70	60,000/60°C		
<b>109R0605F401</b>			0.20	1.00	3,200	0.44 15.5	29.4 0.118	24	-20 to +60			
<b>109R0605M401</b>			0.13	0.65	2,600	0.36 12.7	19.6 0.079	20	-20 to +70			
<b>109R0612J401</b>	12	10.8 to 13.2	0.47	5.64	7,600	1.06 37.1	155.0 0.622	44	-20 to +60	40,000/60°C		
<b>109R0612G401</b>			0.24	2.88	5,600	0.78 27.5	87.3 0.351	39	-20 to +70			
<b>109R0612D401</b>		10.2 to 13.8	0.21	2.52	5,150	0.72 25.4	73.5 0.295	37	-20 to +70			
<b>109R0612S401</b>			6 to 13.8	0.17	2.04	4,600	0.65 23.0	56.8 0.228	33		-20 to +70	
<b>109R0612H401</b>				0.11	1.32	3,800	0.53 18.7	40.1 0.161	28		-20 to +70	
<b>109R0612F401</b>		7 to 13.8	0.09	1.08	3,200	0.44 15.5	29.4 0.118	24	-20 to +70			
<b>109R0612M401</b>			0.06	0.72	2,600	0.36 12.7	19.6 0.079	20	-20 to +70			
<b>109R0624J401</b>		24	21.6 to 26.4	0.24	5.76	7,600	1.06 37.1	155.0 0.622	44		-20 to +60	40,000/60°C
<b>109R0624G401</b>			20.4 to 27.6	0.13	3.12	5,600	0.78 27.5	87.3 0.351	39		-20 to +70	
<b>109R0624D401</b>	12 to 27.6		0.12	2.88	5,150	0.72 25.4	73.5 0.295	37	-20 to +70			
<b>109R0624S401</b>			0.08	1.92	4,600	0.65 23.0	56.8 0.228	33	-20 to +70			
<b>109R0624H401</b>			0.06	1.44	3,800	0.53 18.7	40.2 0.161	28	-20 to +70			
<b>109R0624F401</b>	14 to 27.6		0.05	1.20	3,200	0.44 15.5	29.4 0.118	24	-20 to +70			
<b>109R0624M401</b>			0.04	0.96	2,600	0.36 12.7	19.6 0.079	20	-20 to +70			
<b>109R0648J401</b>	48		43.2 to 52.8	0.12	5.76	7,600	1.06 37.1	155.0 0.622	44	-20 to +60	40,000/60°C	
<b>109R0648G401</b>		43 to 53	0.07	3.36	5,600	0.78 27.5	87.3 0.351	39	-20 to +70			
<b>109R0648H401</b>		40 to 53	0.04	1.92	3,800	0.53 18.7	40.2 0.161	28	-20 to +70			

Other sensor specifications are available as options. Please refer to the index (pp. 498 to 499).

## Dimensions (unit: mm) (With ribs)

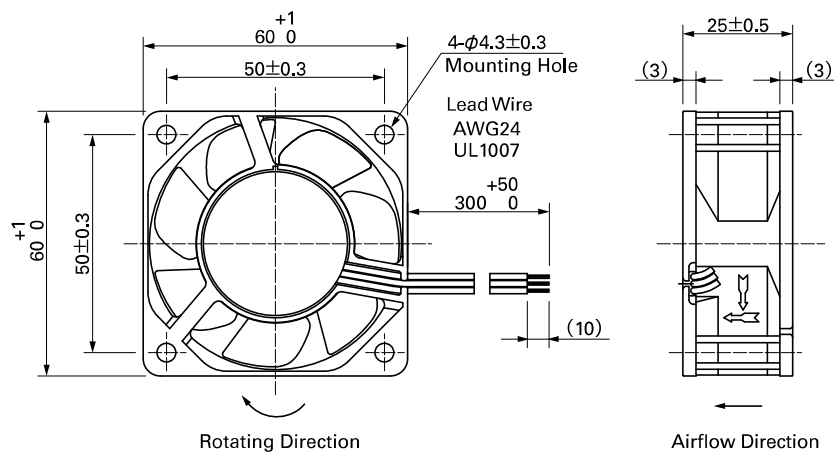

**Reference Dimensions of Mounting Holes and Vent Opening (unit: mm)**

Inlet side, Outlet side

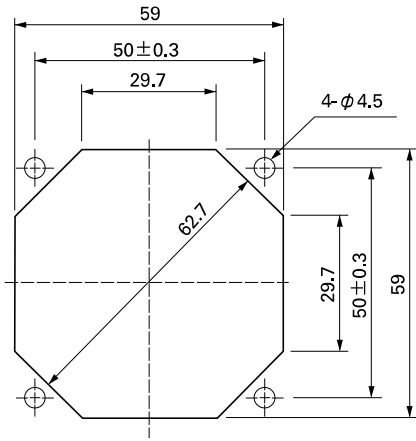

**Options (unit: mm)**

**Finger Guards**

Model : 109-139E Surface treatment : Nickel-chrome plating (silver) Color : 109-139H : Cation electropainting (black)

Inlet side, Outlet side

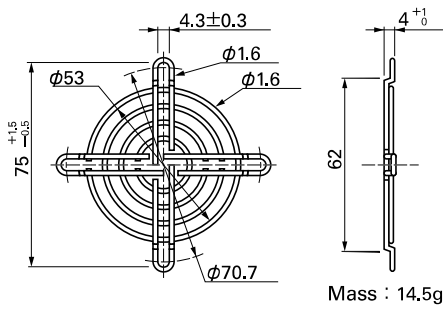

**Resin Finger Guards**

Model : 109-1003G

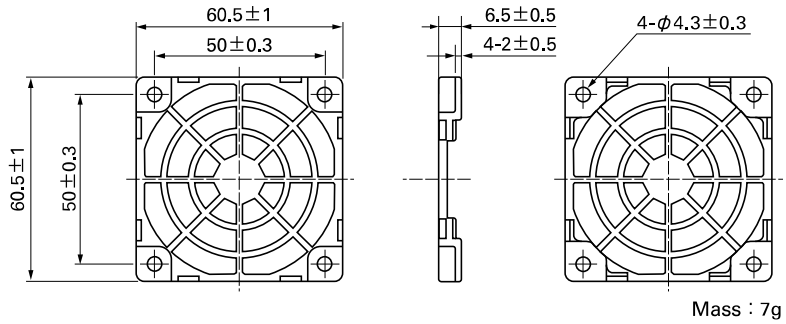

**Resin Filter Kits**

Model : 109-1003F13 (13PPI), 109-1003F20 (20PPI)  
: 109-1003F30 (30PPI), 109-1003F40 (40PPI)

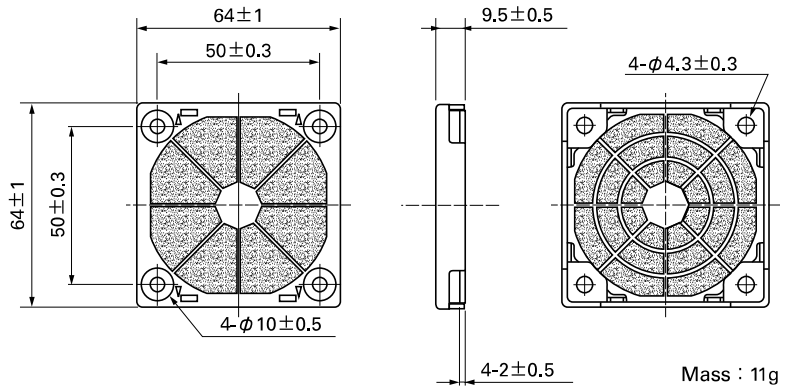

**60** mm sq.

**San Ace 60**

**60×60×25**mm [Mass : 90g]

**Airflow - Static Pressure Characteristics**

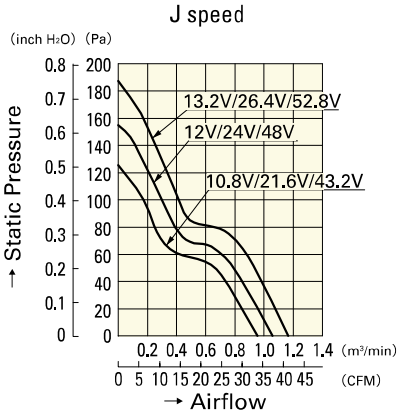

**109R0612J401**  
**109R0624J401**  
**109R0648J401**

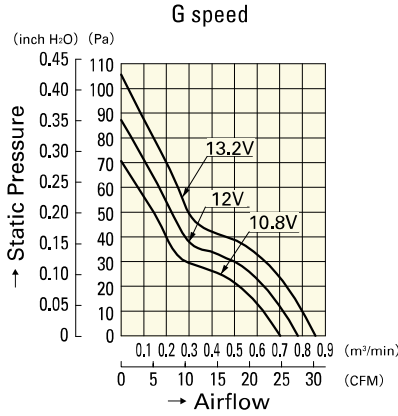

**109R0612G401**

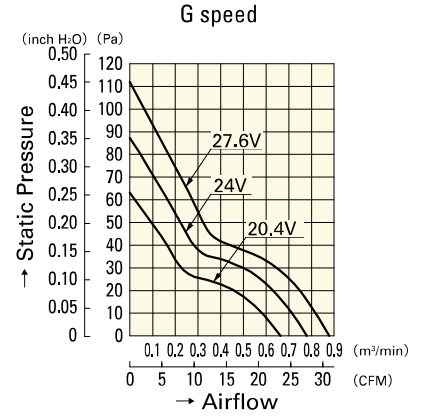

**109R0624G401**

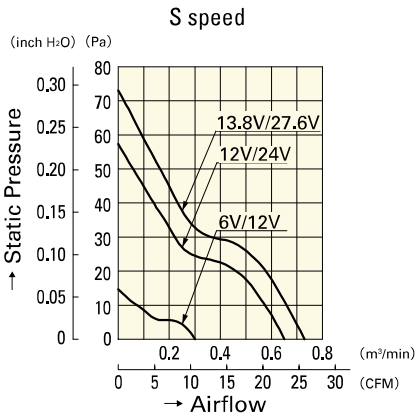

**109R0612S401**  
**109R0624S401**

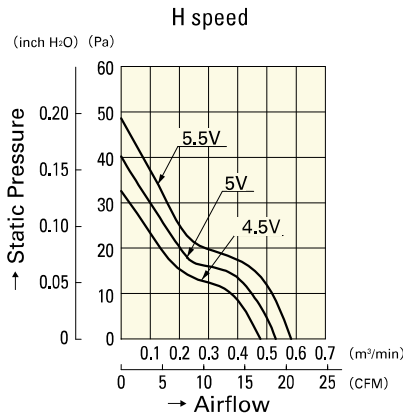

**109R0605H401**

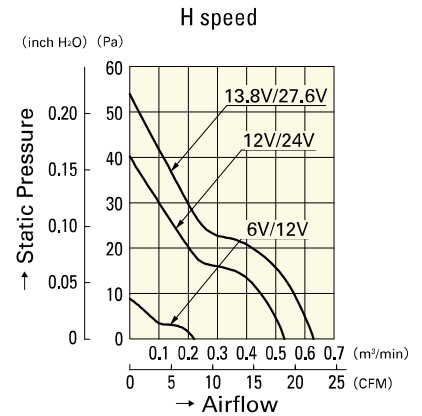

**109R0612H401**  
**109R0624H401**

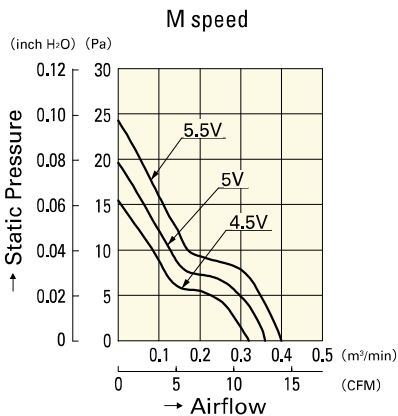

**109R0605M401**

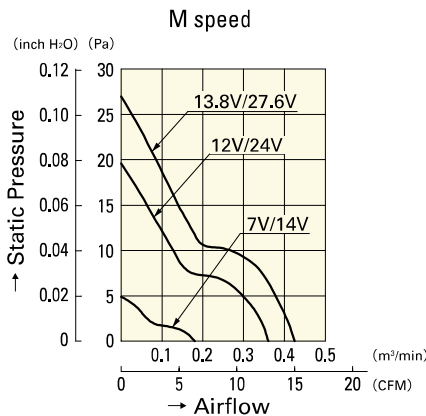

**109R0612M401**  
**109R0624M401**

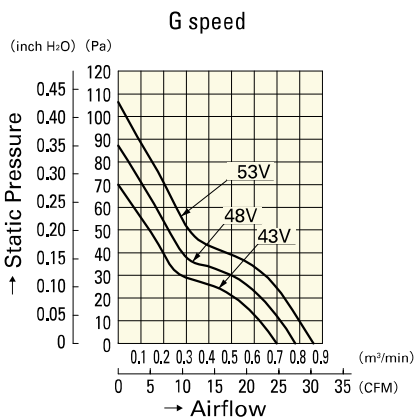

**109R0648G401**

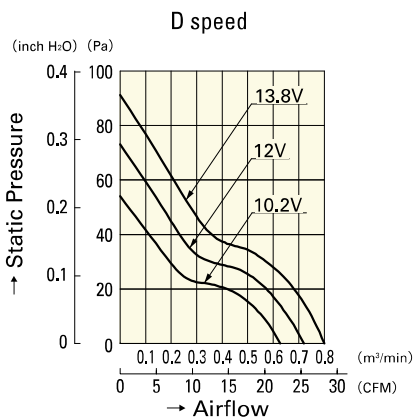

**109R0612D401**

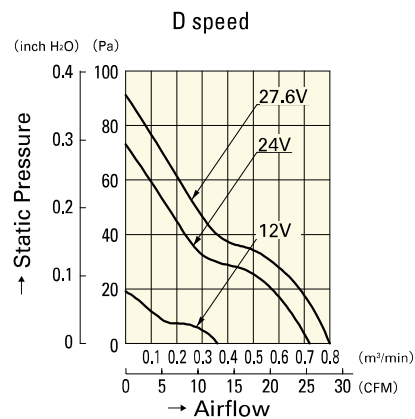

**109R0624D401**

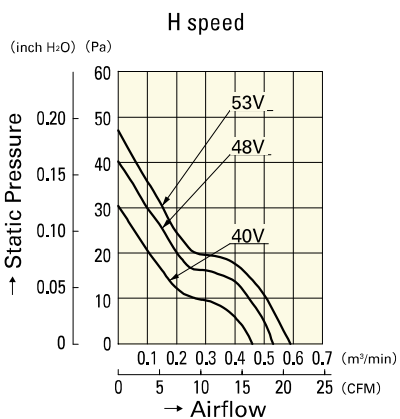

**109R0648H401**

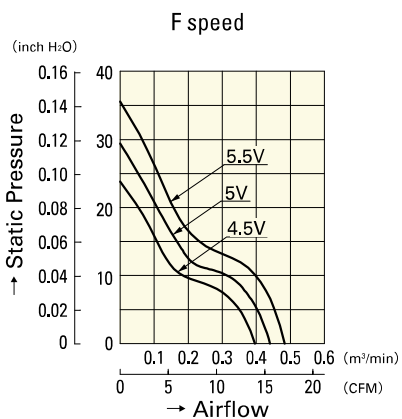

**109R0605F401**

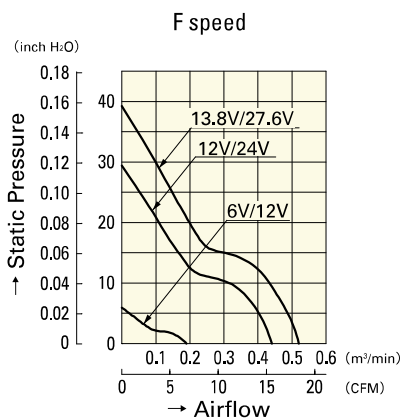

**109R0612F401**

**109R0624F401**