

**80** mm sq.

# San Ace 80



## General Specifications

- Material ..... Frame: Plastics (Flammability: UL94V-0),  
Impeller: Plastics (Flammability: UL94V-0)
- Expected Life ..... Refer to specifications (L10:Survival rate:90% at 60°C ,  
rated voltage, and continuously run in a free air state)
- Lead Wire ..... ⊕red ⊖black (Sensor) yellow
- Storage Temperature ..... -30°C to +70°C (Non-condensing)

**80×80×38**mm [Mass : 170g] **9G type**

## Specifications

The following nos. **have pulse sensors and ribs**. For ribless, append "1" to the model no.

Model No.	Rated Voltage [V]	Operating Voltage Range [V]	Rated Current [A]	Rated Input [W]	Rated Speed [min <sup>-1</sup> ]	Max. Airflow [m <sup>3</sup> /min] [CFM]	Max. Static Pressure [Pa] [inchH <sub>2</sub> O]	SPL [dB(A)]	Operating Temperature [°C]	Expected Life [h]
<b>9G0812K101</b>	12	10.8 to 13.2	1.8	21.6	7,800	3.10 107.3	310 1.285	58	-20 to +60	40,000/60°C
<b>9G0812G101</b>		7 to 13.8	1.1	13.2	6,300	2.55 90	211 0.847	51		
<b>9G0812H101</b>			0.9	10.8	5,700	2.28 80	171 0.687	49		
<b>9G0824G101</b>	24	20.4 to 27.6	0.56	13.4	6,300	2.55 90	211 0.847	51		
<b>9G0824H101</b>			0.42	10.1	5,700	2.28 80	171 0.687	49		
<b>9G0848G101</b>	48	40.8 to 55.2	0.27	13.0	6,300	2.55 90	211 0.847	51		
<b>9G0848H101</b>			0.20	9.6	5,700	2.28 80	171 0.687	49		

Other sensor specifications are available as options. Please refer to the index (p. 502).

## Dimensions (unit: mm) (With ribs)

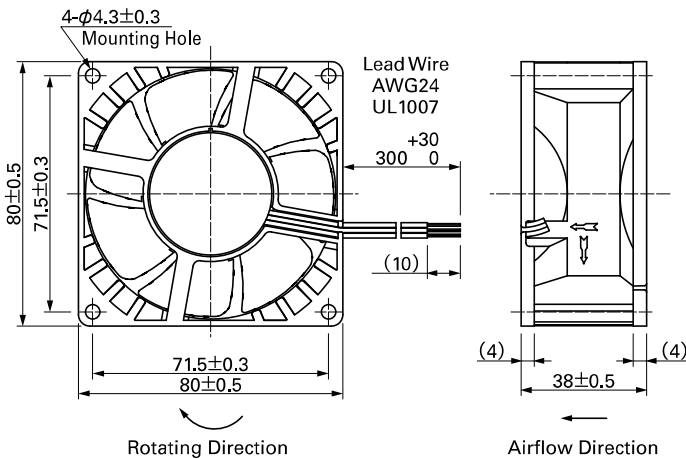

## Reference Dimensions of Mounting Holes and Vent Opening (unit: mm)

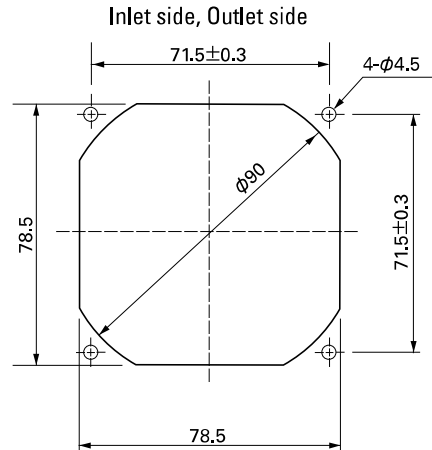

**Options (unit: mm)**

**Finger Guards**

Model : 109-049C Surface treatment : Nickel-chrome plating (silver) Color : Nickel-chrome plating (silver)

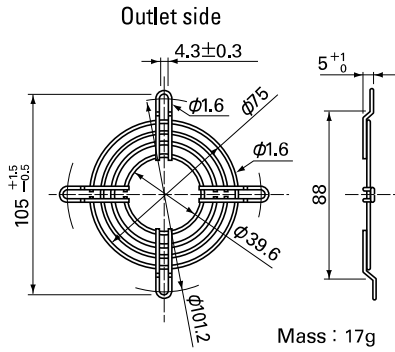

**Resin Finger Guards**

Model : 109-1002G

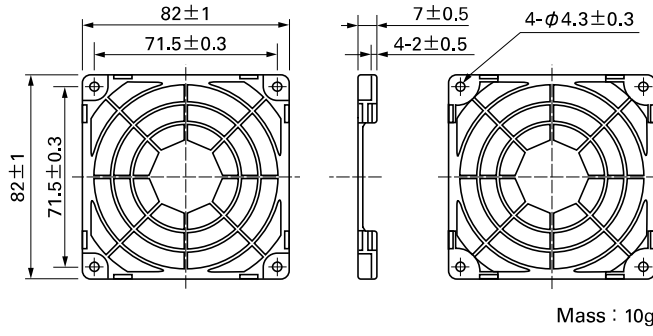

Model : 109-049E Surface treatment : Nickel-chrome plating (silver) Color : Nickel-chrome plating (silver)  
: 109-049H : Cation electropainting (black)

**Inlet side, Outlet side**

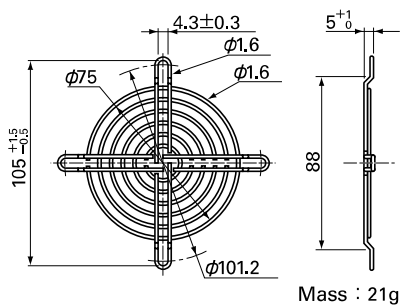

**Resin Filter Kits**

Model : 109-1002F13 (13PPI), 109-1002F20 (20PPI)  
: 109-1002F30 (30PPI), 109-1002F40 (40PPI)

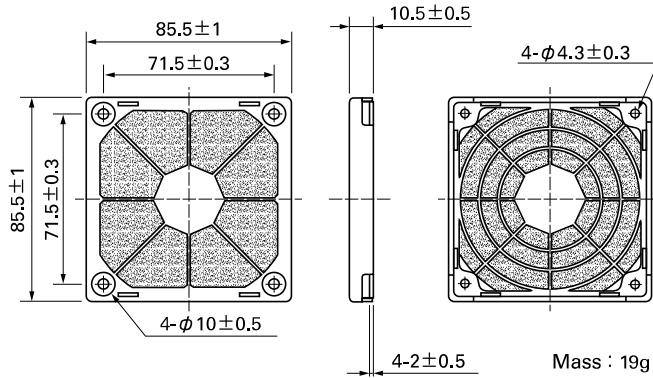

**Airflow - Static Pressure Characteristics**

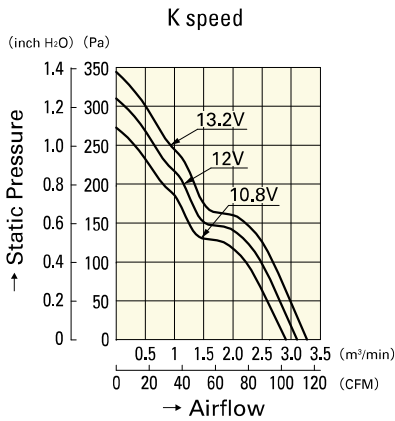

**9G0812K101**

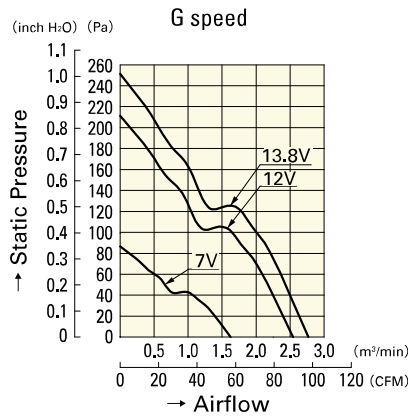

**9G0812G101**

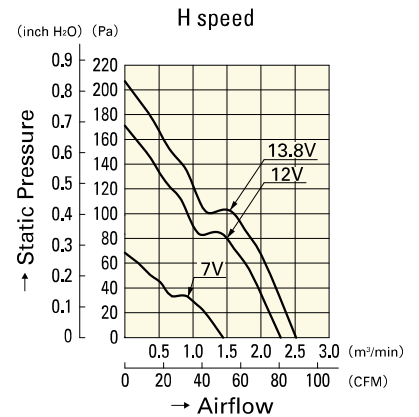

**9G0812H101**

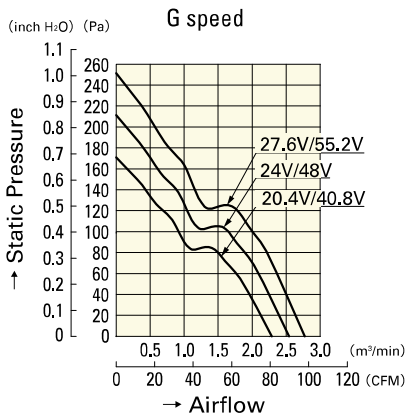

**9G0824G101**  
**9G0848G101**

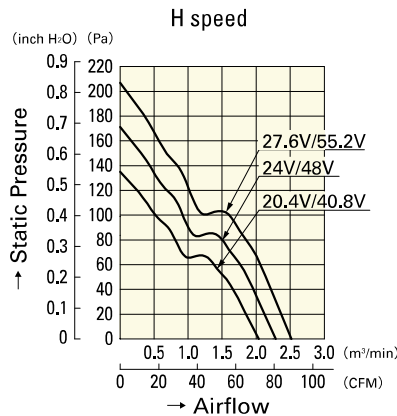

**9G0824H101**  
**9G0848H101**